

# G24 SERIES 24" TRAVEL AUTOGAUGES

The G24 series is designed for applications where 24" of front to rear travel is desired. Each system features Automec's DC motor drive which is backed up by an electro-mechanical disc brake once the backgauge reaches position. This drive system is known for its high reliability and holding force.

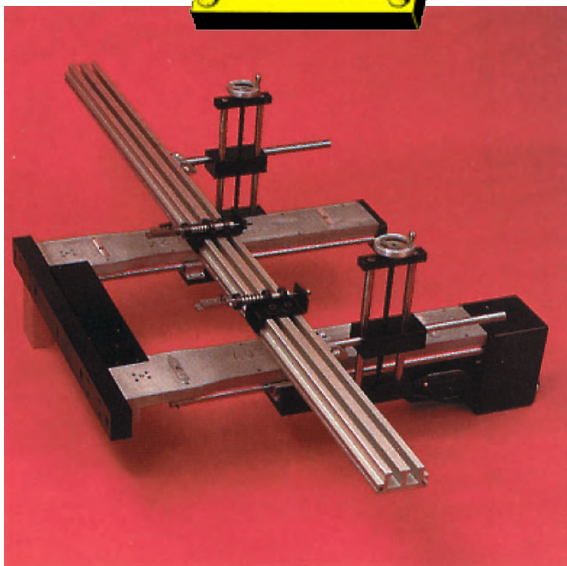
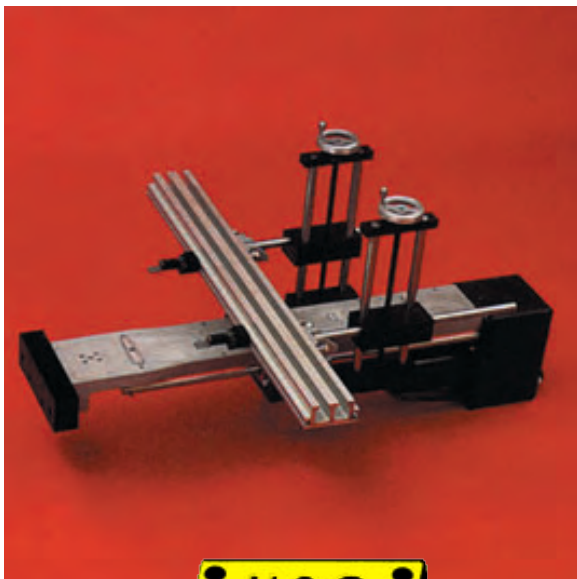

MODEL	A
Holding Force	200 lbs.
# of Drives	1
Weight	200 lbs.
Overall Height	26"
Overall Depth	45"
Overall Width	16"
Gauge Bar Length	3'
Positioning Speed	600 IPM
Gauge Travel	24"
Repeatability	±.002"
Vertical Height Adjustment	10"
Recommended Width	Up to 4'

The A compact gauge for press brakes with 12" to 42" between sideframes. This unit is available with a 3' gauge bar for light applications.

MODEL	BP	HD/P
Holding Force	400lbs.	
# of Drives	2	
Weight	300 lbs.	
Overall Height	26"	
Overall Depth	45"	
Overall Width	40"	
Gauge Bar Length	7'	
Positioning Speed	600 IPM	
Gauge Travel	24"	
Repeatability	±.002"	
Vertical Height Adjustment	10"	
Recommended Pressbrake Side frame Width	5' to 8' 6"	

The P models are required for Amada, Promecam, and other brakes in which the rear bed clearance is less than 7". This low-profile backgauge bolts right to the die rail.

**AUTOMECH**

82 CALVARY STREET  
WALTHAM, MA 02453-5918

Telephone: 781-893-3403 • Fax: 781-899-5708  
E-mail: automec@automec.com

**WEBSITE: WWW.AUTOMECH.COM**

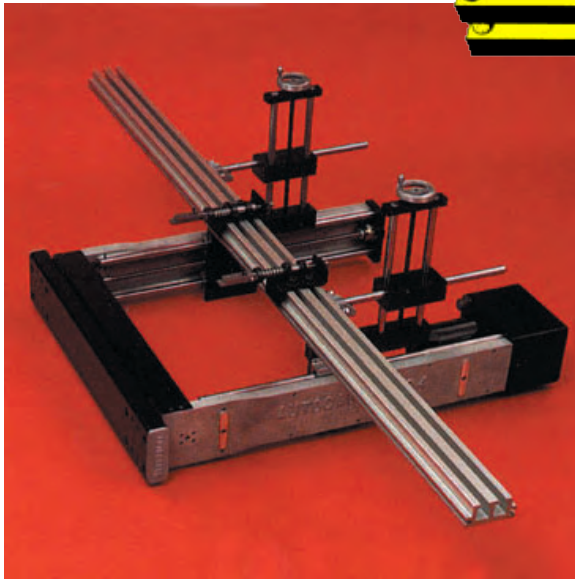

MODEL	B
Holding Force	400lbs.
# of Drives	2
Weight	300 lbs.
Overall Height	26"
Overall Depth	45"
Overall Width	40"
Gauge Bar Length	7'
Positioning Speed	600 IPM
Gauge Travel	24"
Repeatability	± .002"
Vertical Height Adjustment	10"
Recommended Pressbrake Sideframe Width	5' to 8'6"

The B is Automec's most popular model. Ideal for pressbrakes with up to 8'6" between the sideframes.

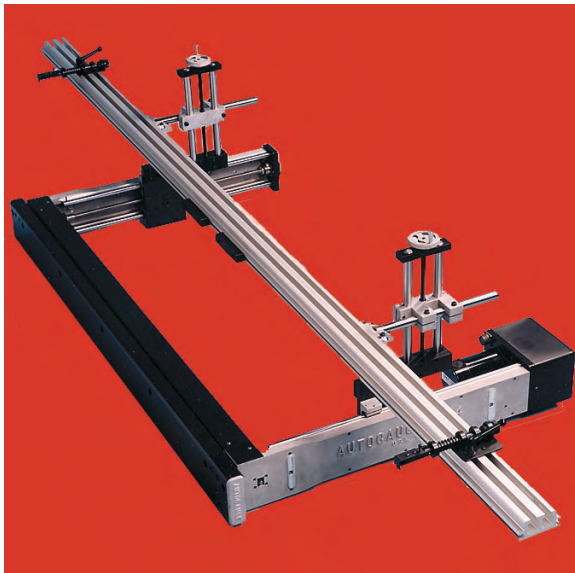

MODEL	HD
Holding Force	400lbs.
# of Drives	2
Weight	300 lbs.
Overall Height	26"
Overall Depth	45"
Overall Width	77"
Gauge Bar Length	11'
Positioning Speed	600 IPM
Gauge Travel	24"
Repeatability	± .002"
Vertical Height Adjustment	10"
Recommended Pressbrake Sideframe Width	9' to 14'

The HD heavy-duty offers more rigidity for larger pressbrakes or when progressive die set-ups are used.

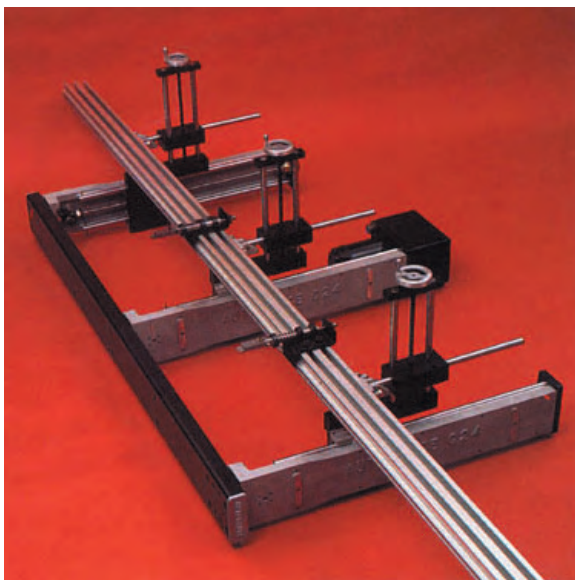

MODEL	TD
Holding Force	600lbs.
# of Drives	3
Weight	450 lbs.
Overall Height	26"
Overall Depth	45"
Overall Width	148"
Gauge Bar Length	18'
Positioning Speed	600 IPM
Gauge Travel	24"
Repeatability	± .002"
Vertical Height Adjustment	10"
Recommended Pressbrake Sideframe Width	over 14'

The TD has 3 drive screws with the center drive flanked by 2 drives 6' away on each side. Designed for large bed pressbrakes.