

Ram Cushions and Pressure Parallels



Hyson™ Products
Associated Spring 



Dynamic Solutions For A Global Market™



Table of Contents

	Page
Introduction.....	2
The Advantages.....	3
The Components.....	6
The Pressure Styles.....	8
The Mounting Styles.....	9
The Cylinder Styles.....	10
An Alternative-Pressure Parallels.....	11

Introduction



Hyson Products Nitro-Dyne® nitrogen ram cushions offer a variety of advantages over conventional hydraulic and air ram cushions, from design flexibility and lower tooling costs to consistent force and simple retrofits.

It is not surprising that Hyson ram cushions are the choice of metal stampers worldwide. For almost 75 years, Hyson Products has been engineering and manufacturing nitrogen gas springs and manifold systems, always working to design products that meet customer needs.

Does the Nitro-Dyne nitrogen ram cushion fit your needs? Read on.

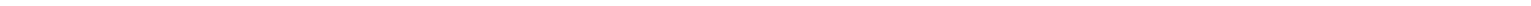

The Advantages

Lower Tooling Costs

Not only is the Nitro-Dyne nitrogen ram cushion less expensive to buy than conventional hydraulic or air ram cushions, but the placement on the ram instead of the die reduces the size and cost of the die. Its versatility reduces tooling costs as well. One nitrogen ram cushion can serve as a pressure system for multiple dies and can be used in a variety of applications by placing it in different presses. Move cylinders to wherever force is needed, and place an unused cylinder or internal hex plug in cavities where no force is required.

Balance Problems Eliminated

The Nitro-Dyne ram cushion cylinders can be placed at each die push-pin location. Because each cylinder operates independently, there is no need to balance the ram cushion. Hydraulic and air ram cushions require careful balancing to eliminate uneven loads that can damage the press, cushion or die.

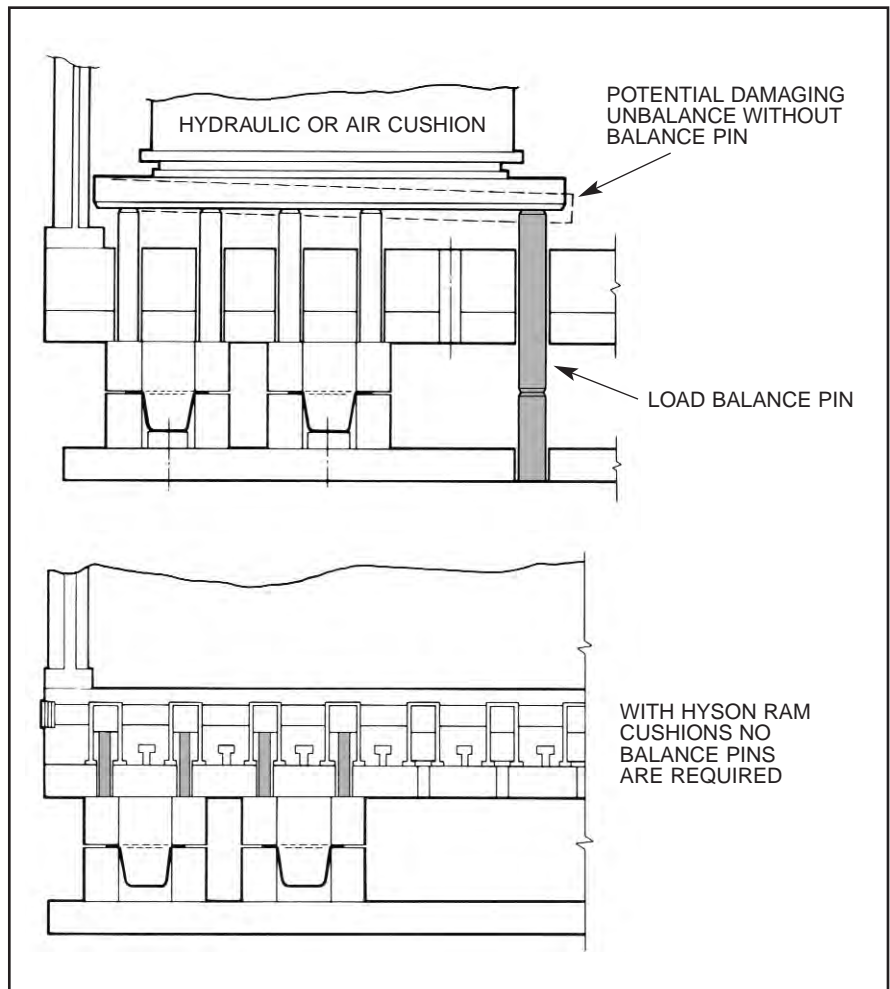

Nitro-Dyne® Ram Cushions and Pressure Parallels

Force Flexibility

Nitro-Dyne ram cushion cylinders allow you to change pressure while the cushion is still attached to the ram. There is no downtime or lost production. To adjust the force, simply add or remove nitrogen gas by means of the control panel. You can check the pressure gauge for a repeatable pressure reading.

Cylinder Design

Hyson ram cushion cylinders are available in two, four and six ton force capacities with stroke lengths up to eight inches. Cylinder pistons are designed to accommodate your specific die push-pin requirements, and are available with slip fit guide bushings or press fit.



Consistent Force with Every Stroke

The Nitro-Dyne ram cushion is a closed system and applies the same force with every stroke to ensure the consistently high quality of each and every part. The force in a conventional air ram can fluctuate as air demands change throughout the plant.

Reduced Operating Costs

The costs to operate Hyson's Nitro-Dyne ram cushion systems are significantly less than hydraulic or air ram cushions for several reasons:

- A compressor or expansion tank is not required.
- Cylinders can be checked and adjusted in minutes while the hydraulic and air ram cushions often require partial disassembly of the press in order to make repairs.
- Downtime is minimized, especially in transfer press lines. In the event of a leak, a spare cylinder can be exchanged within minutes and the original cylinder repaired while production continues uninterrupted.

Smaller, Quieter Operation

The Nitro-Dyne ram cushion system requires less space than conventional air ram cushions of equal stroke, and has less metal-to-metal contact so less noise is generated by the press.

Constant Force throughout the Stroke

The Nitro-Dyne ram cushion system is engineered for nearly constant force throughout the stroke, a critical factor in controlling the flow of material. Constant force is difficult to achieve with a conventional air ram cushion because pressure build-up is controlled by the air valves and expansion tank required by the cushion.

Simple Retrofits

Compatible with most presses and dies, the ram cushion cylinders can be placed at any location where force is needed. Cylinder cavities are usually located at JIC or ISO centers.



Nitro-Dyne® Ram Cushions and Pressure Parallels

The Components

Ram Cushion Plate

- Machined to customer specifications and finished top and bottom.
- Holds cylinders in proper position and serves as reservoir for nitrogen gas.

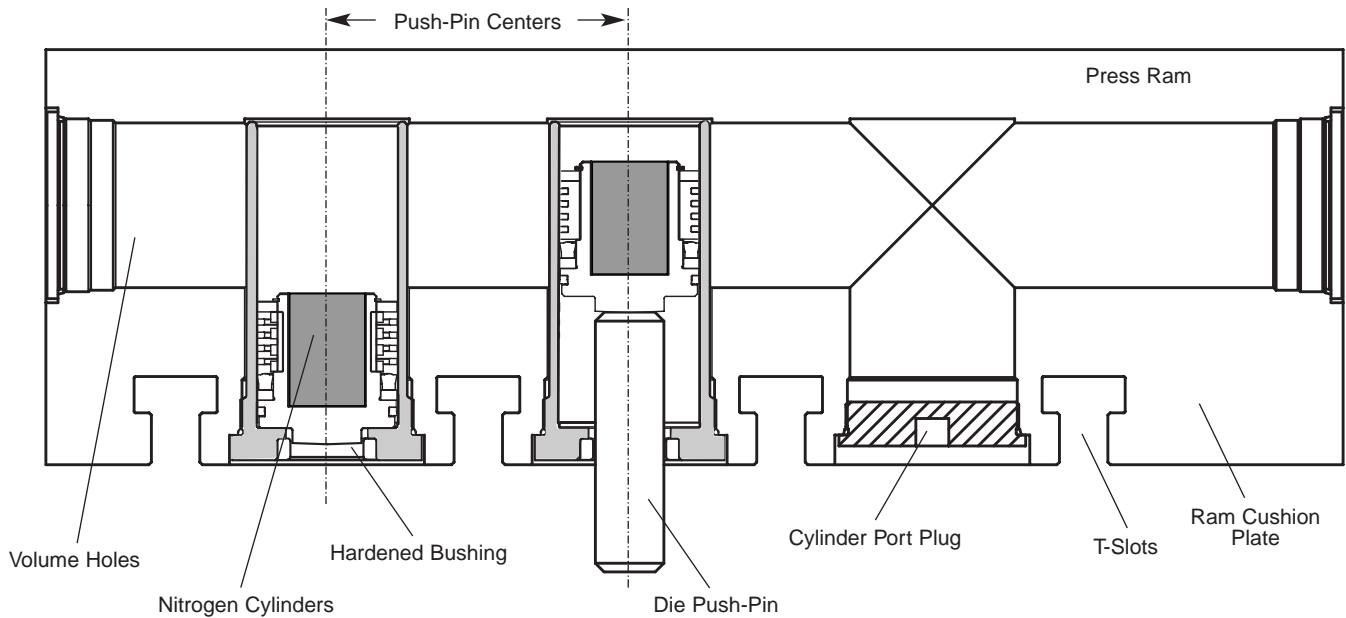

Nitrogen Cylinders

- Threaded into the cushion plate and sealed by an o-ring.
- Connected to the reservoir so that all cylinders provide the same force.
- Feature a pressure relief groove through which nitrogen gas escapes if an attempt is made to remove a cylinder before it is discharged. The sound of escaping gas warns that the system is still under pressure. No further services should be done until the system is completely discharged.

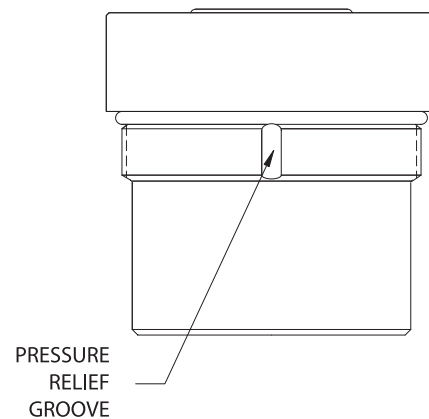



Volume Holes

- Drilled through the ram cushion plate.
- Allow common pressure throughout the system and act as nitrogen gas reservoirs.

Die Push-Pin

- Can be inserted in any cylinder position.
- Transfers force from the cylinder to the die.

Ram Cushion Plugs

- Threaded into the ram cushion plate and sealed by an o-ring.
- Provide closure to reservoir drillings.

Control Panel

- Contains all necessary controls for charging, exhausting and reading pressure in the system.
- Can be sealed directly to the ram cushion plate or attached remotely with a hose.
- Available in a variety of styles for specific applications.

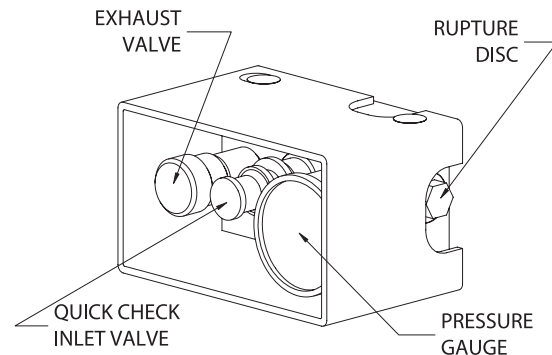

Rupture Disc

- Contained on all Hyson ram cushion systems to guard against overpressure conditions.
- Located on the control panel when the control panel is bolted to the ram cushion plate.
- Located on both the control panel and the ram cushion plate when the control panel is mounted remotely.

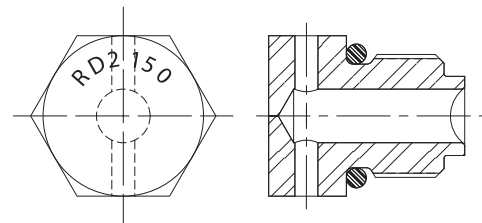

T-Slots

- Machined into the ram cushion in the same mounting pattern as in the ram face.
- Allow the upper die to be mounted to the cushion.

Nitro-Dyne® Ram Cushions and Pressure Parallels

The Pressure Styles

Common Pressure System

Most ram cushions are designed with a common nitrogen pressure throughout the system. Cylinders are connected by volume holes drilled the length of the cushion plate. The volume holes serve as reservoirs for nitrogen gas.

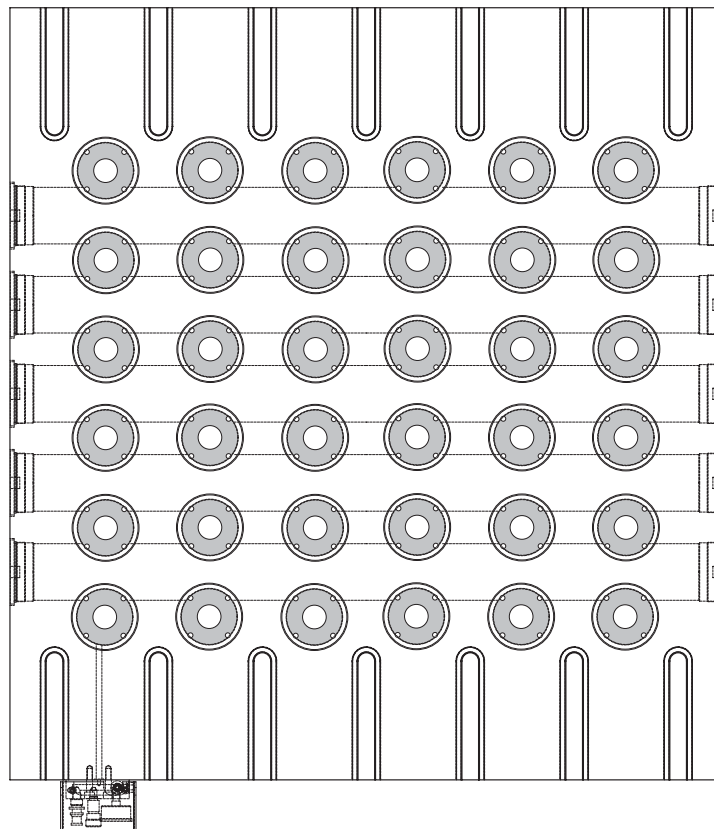

Zone Pressure System

Some ram cushions are engineered to have zones of varying force. Each zone operates independently. If an application calls for a common pressure area, a connector can be used to join two or more cylinder zones.

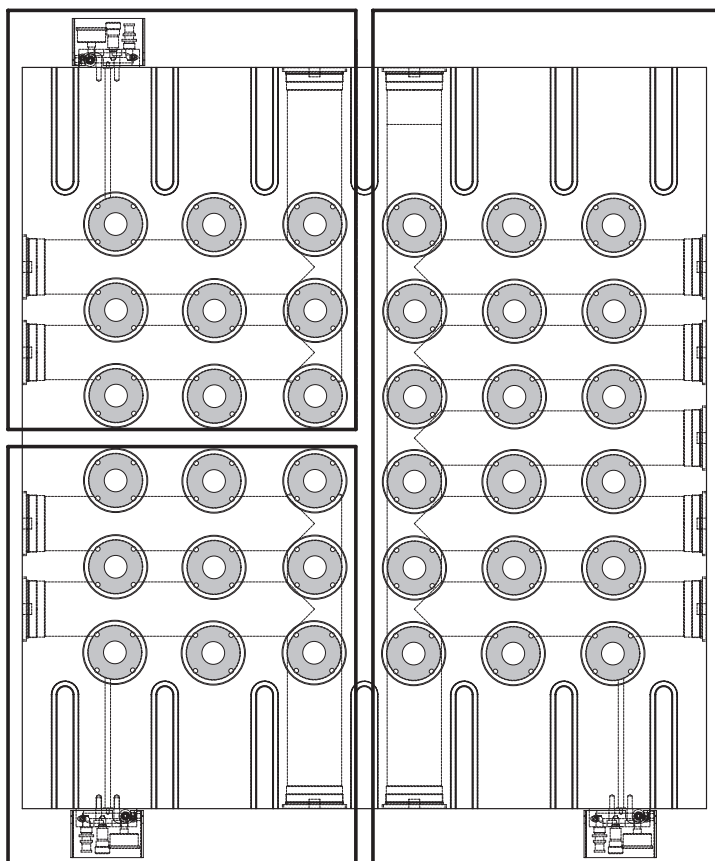



The Mounting Styles

Mount to Ram Face

T-slots are machined into the ram cushion in the same mounting pattern as in the ram face. Mounting holes are also machined into the cushion plate to bolt it to the press ram. If needed, pockets are machined into the plate perimeter to match hydraulic clamping requirements.

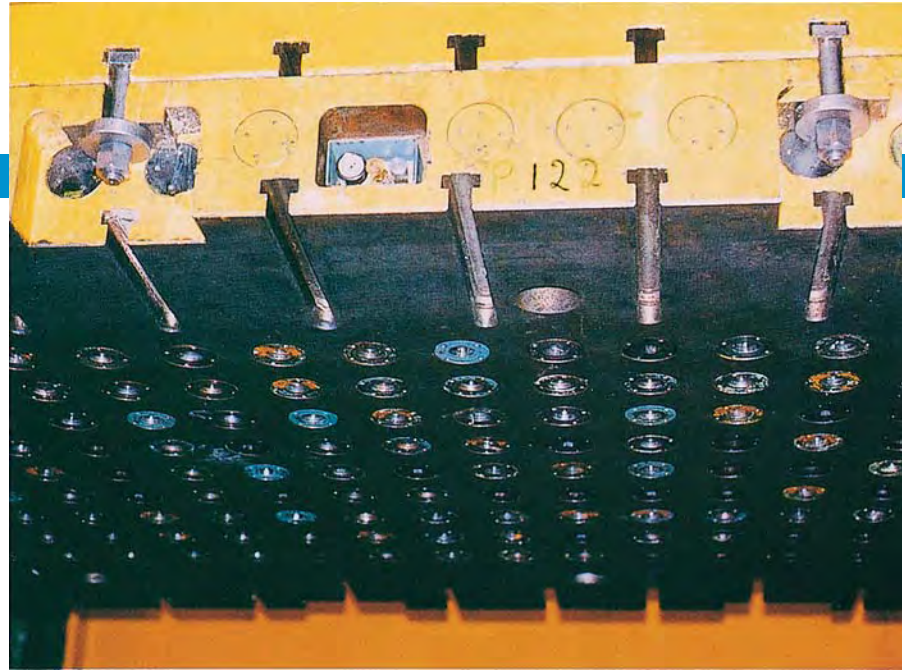

Insert into Ram Face

A pocket is machined in the ram face and the cushion is bolted into place. This mounting style is preferred because it allows the maximum amount of press shut height.



Design Considerations

Proper alignment between the cushion and press ram, and between the cushion and die push-pin is extremely important.

The weight of the largest nitrogen ram cushion and die, as well as the weight capacity of the press, should be considered.



The Cylinder Styles

Retained Bushing

Notes:

Stroke lengths are based on customer specifications.

Optional modifications include extended boss and extended sleeve head for larger T-slots. Contact Hyson Products' Customer Service Department.

When ordering, please specify diameter of die push-pin to be used, and die open clearance required between cylinder piston and die push-pin.

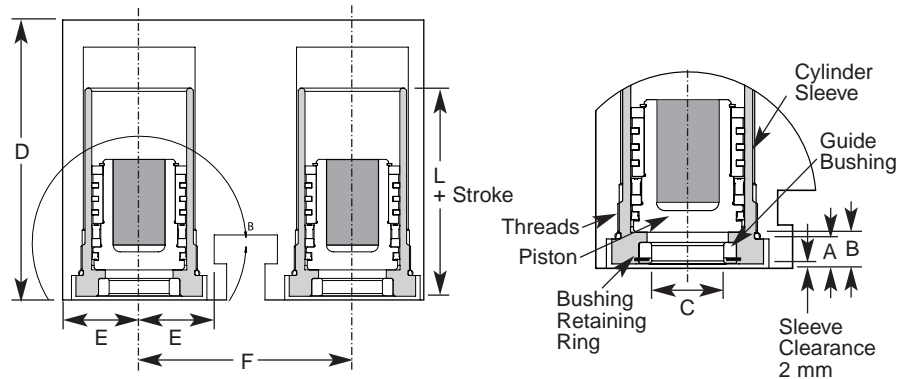

Standard Ram Cushion w/Retained Bushing Dimensions

Cylinder Model RT	A C'bore Depth Includes 2 mm	B Die Open Includes 2 mm Clear	C Bushing ID	D Minimum Plate Thickness	E Minimum Edge Distance	F Cylinder Center to Center	Cylinder Threads	L + Stroke
RC-2	11.4 mm 0.45 in.	39.6 mm 1.56 in.	27.0 mm 1.06 in.	110 mm + stroke 4.33 in. + stroke	39.6 mm 1.56 in.	150.0 mm 6.00 in.	2 1/2-12	82.6 mm 3.25 in.
RC-4	17.2 mm 0.68 in.	34.2 mm 1.35 in.	39.6 mm 1.56 in.	140 mm + stroke 5.50 in. + stroke	54.0 mm 2.12 in.	150.0 mm 6.00 in.	M82X2	102.1 mm 4.02 in.

Pressed-in Bushing

Notes:

Stroke lengths are based on customer specifications.

Optional modifications include extended boss and extended sleeve head for larger T-slots. Contact Hyson Products' Customer Service Department.

When ordering, please specify diameter of die push-pin to be used, and die open clearance required between cylinder piston and die push-pin.

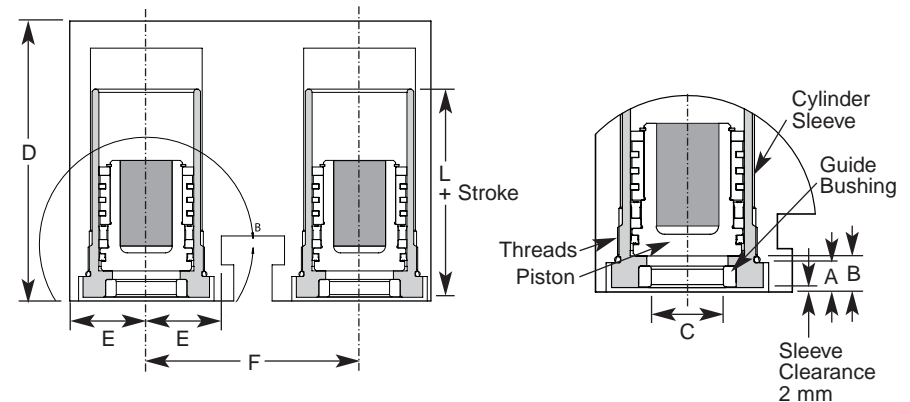

Standard Ram Cushion w/Pressed-in Bushing Dimensions

Cylinder Model PF	A C'bore Depth Includes 2 mm	B Die Open Includes 2 mm Clear	C Bushing ID	D Minimum Plate Thickness	E Minimum Edge Distance	F Cylinder Center to Center	Cylinder Threads	L + Stroke
RC-2B	11.4 mm 0.45 in.	39.6 mm 1.56 in.	27.0 mm 1.06 in.	110 mm + stroke 4.33 in. + stroke	39.6 mm 1.56 in.	150.0 mm 6.00 in.	2 1/2-12	82.6 mm 3.25 in.
RC-4B	16.8 mm 0.66 in.	20.5 mm 0.81 in.	39.6 mm 1.56 in.	120 mm + stroke 4.72 in. + stroke	54.0 mm 2.12 in.	150.0 mm 6.00 in.	M82X2	80.8 mm 3.18 in.
RC-6B	16.8 mm 0.66 in.	20.5 mm 0.81 in.	39.6 mm 1.56 in.	120 mm + stroke 4.72 in. + stroke	63.5 mm 2.50 in.	150.0 mm 6.00 in.	M100X2	80.8 mm 3.18 in.



An Alternative – Pressure Parallels

all the advantages of the Nitro-Dyne nitrogen ram cushion in a smaller space.

When pressure flexibility is required and space is at a premium, choose pressure parallels. Pressure parallels take advantage of the high force and short overall height of the RC cylinders, and provide die pressure units built completely into precision-sized spacers or parallels. You can position each parallel where needed and easily adjust pressure from zero to full cylinder capacity of two tons at 103 bar (1500 psi).

For higher tonnage applications, two or more parallels can be positioned side by side. This configuration repeats the side-to-side and front-to-back JIC/ISO push-pin locations of Nitro-Dyne full ram cushions. Interconnecting small hoses between the parallels allows operation at a common pressure.

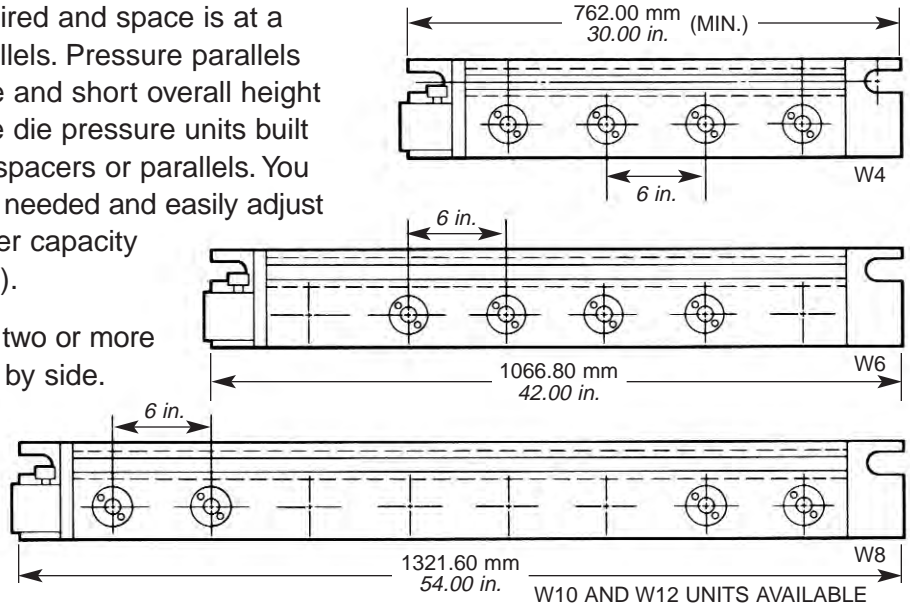

Flexible Design

Nitro-Dyne pressure parallels are available with a single cylinder mounting port or as many 12 in a parallel up to 96" long. Many users require the parallel to cover the ram face, front to back. When only a few cylinders are needed, the parallel can be extended between or outside the end cylinders (See Figure 1 and Dimension Chart).

Tee Mounting

A tee mounting slot machined down the length of each parallel maintains the same mounting pattern as the ram face.

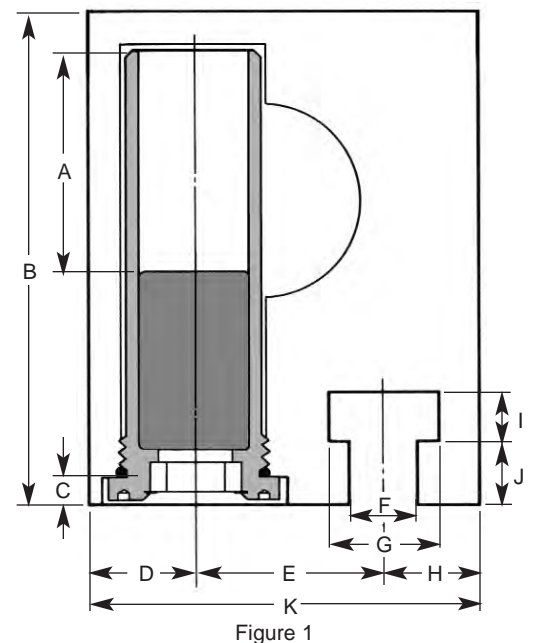

RC-2 Pressure Parallel Dimensions (JIC Tee Slot)

A Travel	B	C	D	E	F	G	H	I	J	K
76.2 mm 3.00 in.	203.20 to 203.25 mm 8.000 to 8.002 in.	39.6 mm 1.56 in.	39.6 mm 1.56 in.	76.2 mm 3.00 in.	28.0 mm 1.06 in.	46.0 mm 1.84 in.	36.5 mm 1.44 in.	20.0 mm 0.83 in.	36.0 mm 1.25 in.	149.62 to 150.0 mm 5.985 to 6.00 in.