

Nitrogen Gas Springs for High Speed Stamping

# Tanker® XP Series

## TNK-400HS

### The TNK-400HS Features

- Long Service Life  
*Engineered for service life of 25 million cycles, without recharge.*
- Preloaded by Gas Pressure  
*Does not require keeper assemblies or guides. Does not require compression in the die to preload.*
- High Speed Capable  
*Life tested at speeds over 600 spm.*
- Available as Hosed System  
*For equal force across the die. Can be recharged in the die.*
- Adjustable  
*Force can be adjusted by reducing gas pressure. Pressure in hosed systems can be adjusted in the die.*
- Variety of Mounting Options  
*Provides flexibility in die design. Offers potential shut height reduction.*

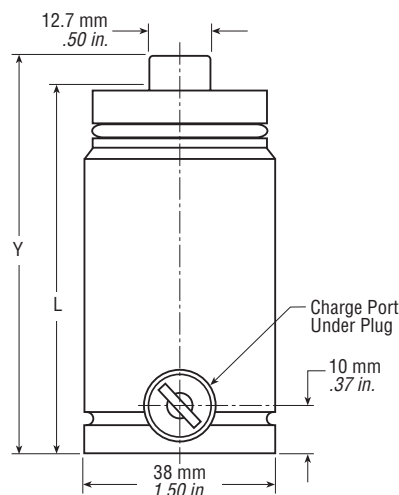

### TNK-400HS Dimensional Information

Part Number	Effective Piston Area		Maximum Force at 150 bar/2175 psi		Maximum Stroke		Y		L	
	cm <sup>2</sup>	in <sup>2</sup>	kN	lbs.	mm	in	mm	in	mm	in
TNK-400x.25HS	2.62	0.406	3.94	885	6.35	0.25	82.5	3.25	76.2	3.00
TNK-400x.50HS					12.7	0.50	114.3	4.50	101.6	4.00
TNK-400x.75HS					19.05	0.75	146.1	5.75	127.0	5.00
TNK-400x1.00HS					25.4	1.00	152	6.00	127.0	5.00

**Hyson™ Products**  
Associated Spring®



10367 Brecksville Road, Brecksville, Ohio 44141  
Toll Free 1-800-876-4976 • 440-526-5900  
FAX: 440-838-7684 • www.hysonproducts.com