



High Force and Long Strokes

TANKER[®]T AND TANKER[®]S SERIES

- High force in short heights with contact forces to 15,400 lbs.
- Stroke lengths to 225 mm
- Dynamic lubrication extends spring life
- Bore seal resists contamination and rod damage
- Self-aligning piston rod accepts normal die movement and a degree of sideload
- Nitrided piston rod resists corrosion
- Tested to over one million cycles



Hyson[®] Products
Associated Spring 

Dynamic Solutions for a Global Market[™]





A business of BARNES GROUP INC

Technical Bulletin

Subject: CP-XM Control Panel Recommended for Tanker® S, T and B Series Gas Springs	Date: 03/31/09	Issue: 09-08
	Issued By: C. Hansen	Page: 1 of 1



When Hyson introduced the latest generation of Tanker® gas springs, we also introduced a new control panel, the CP-XM, specifically for use with this line of high performance springs.

Background

Test data showed that the pressures run in a Tanker spring at full stroke were too high to be measured by our standard control panels like the CP-N2 LG. During testing, we often reached the maximum pressure on the standard gauges and were unable to read the true pressure. Constantly being at maximum pressure or beyond can lead to premature gauge failure or a rupture disk bursting.

CP-XM Features

- Pressure gauge reads to 7500 psi/517 bar while standard gauge pegs at 6000 psi/414 bar.
- No rupture disk necessary because all TNK gas springs feature either a rupture disk or a pressure lip.
- Same hole pattern as CP-N2 LG control panel for easy retrofit.

Availability

In stock and ready for order.



Table of Contents

Introduction	2
TNKT 1000	4
TNKT 2400	6
TNKT 4200	8
TNKT 6600	10
TNKT Force Charts	12
TNKT Accessories	13
TNKS 1000	14
TNKS 2400	16
TNKS 4200	18
TNKS 6600	20
TNKS Force Charts	22
TNKS Accessories	23



Introduction

The new Tanker[®]T and Tanker[®]S have the strength, stamina and sheer capacity to get your stamping job done!

High Force in Short Heights

The new TankerT and TankerS, each with four models from which to choose, offer contact forces from 2,700-15,400 lbs. and full stroke forces from 3,900-27,600 lbs. Some models are over an inch shorter than gas springs with comparable forces currently available.

Dynamic Lubrication Extends Gas Spring Life

The patented dynamic lubrication system coats the gas spring wall, piston and seal with oil with every stroke of the press to reduce heat build-up and lower operating temperature which in turn reduces wear on die components and extends performance life.

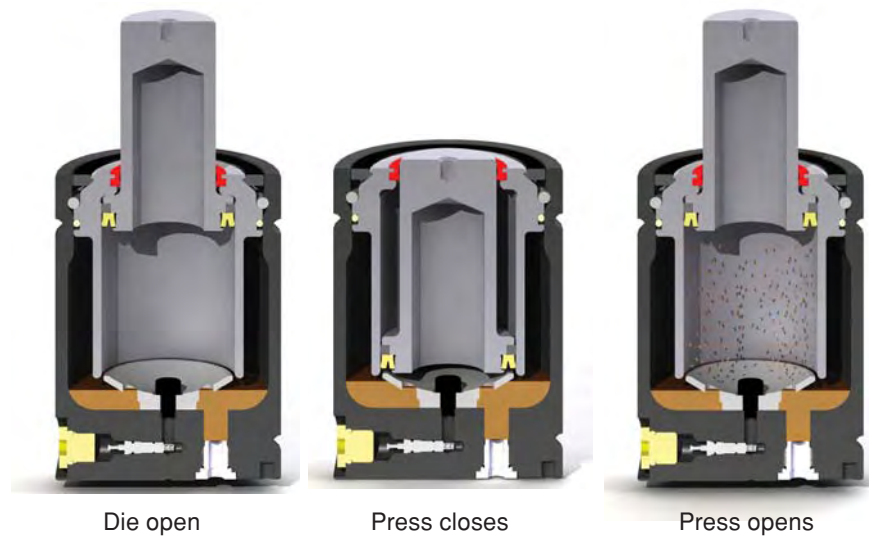

Bore Seal Resists Contamination and Leaking from Rod Damage

Both the TankerT and TankerS seal inside, on the cylinder bore, not on the rod like most gas springs. This provides maximum contamination resistance and keeps the gas spring operating even if the piston rod is damaged.

Self-aligning Piston Rod Accepts Die Movement and a Degree of Sideload

The corrosion-resistant nitrided piston rod is self-aligning, designed to accept normal die movement and a degree of sideload without damaging the sealing surfaces. The TankerT and TankerS have been sideload-tested to over 500,000 strokes.



Stroke Lengths to 225 mm

Long stroke lengths are available on all models.

Self-contained or Hose System Operation

Both the TankerT and TankerS can be used as self-contained gas springs or in a hosed system.



The TankerT (at left) features an SAE-4 (7/16-20) port that uses standard full size hoses while the TankerS (at right) incorporates an M6 or G 1/8 port (depending on model) for use with the Micro EZ® Hose System.

Wide Range of Mounting Options

Both the TankerT and TankerS offer a variety of mounting options, interchangeable with standard mounts currently in use.



Tower Automotive Turns to Shorter, Bore Seal Gas Spring

The Tower Automotive facility in Bardstown, Kentucky, which produces automotive body structures, reworked a die that had been experiencing problems related to excessive sideload. To avoid having to modify the die to accommodate new gas springs, Tower turned to Hyson Products which engineered a new shorter, bore seal gas spring, the Tanker®S to handle the job with no modification to the die required.

The TankerS combines the short height and high force of the T3 Series with the bore seal and dynamic lubrication of the high performance Tanker Series. The bore seal offers maximum protection from sideload and contamination while the dynamic lubrication minimizes heat build-up and optimizes performance life.



TNKT 1000



Product Specifications

Pressure Medium.....Nitrogen Gas
 Maximum Charging Pressure..... 150 bar/2175 psi
 Minimum Charging Pressure..... 25 bar/360 psi
 Max. Operating Temperature 80°C/176°F
 Maximum Piston Rod Velocity96m/min / 315ft/min
 Maximum Utilized Stroke 100%
 Maximum Strokes per Minute..... ~20-100 (dependent on stroke)
 Repair Kit 60-112-7000
 Inlet Valve.....56-072-5500
 Charge Fitting..... T2-770-4

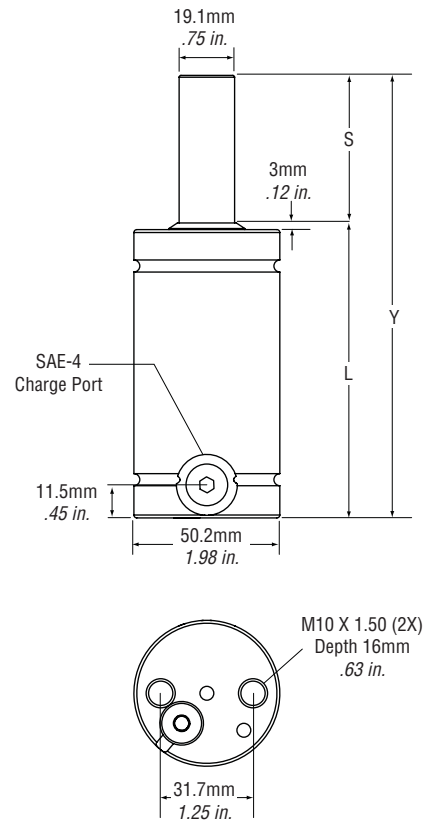

TNKT 1000 Dimensional Information

Model X Stroke	Stroke (S)		Contact Force		Full Stroke Force		L		Y	
	mm	in	N	lbs	N	lbs	mm	in	mm	in
TNKT1000X13	13	0.51	9,630	2,165	16,280	3,660	65	2.56	78	3.07
TNKT1000X16	16	0.63			16,505	3,710	68	2.68	84	3.31
TNKT1000X19	19	0.75			16,660	3,745	71	2.80	90	3.54
TNKT1000X25	25	0.98			16,860	3,790	77	3.03	102	4.02
TNKT1000X32	32	1.26			17,015	3,825	84	3.31	116	4.57
TNKT1000X38	38	1.50			17,080	3,840	90	3.54	128	5.04
TNKT1000X50	50	1.97			17,215	3,870	102	4.02	152	5.98
TNKT1000X63	63	2.48			17,280	3,885	115	4.53	178	7.01
TNKT1000X75	75	2.95			17,325	3,895	127	5.00	202	7.95
TNKT1000X80	80	3.15			17,350	3,900	132	5.20	212	8.35
TNKT1000X100	100	3.94			17,395	3,910	152	5.98	252	9.92
TNKT1000X125	125	4.92			17,435	3,920	177	6.97	302	11.89
TNKT1000X150	150	5.91			17,460	3,925	215	8.46	365	14.37
TNKT1000X175	175	6.89			17,480	3,930	240	9.45	415	16.34
TNKT1000X200	200	7.87	17,505	3,935	265	10.43	465	18.31		



NOTE: All dimensions are nominal. Data shown are typical. Actual data for any particular unit may vary.



Mounting Options

FC

Order No. T2-750-FC

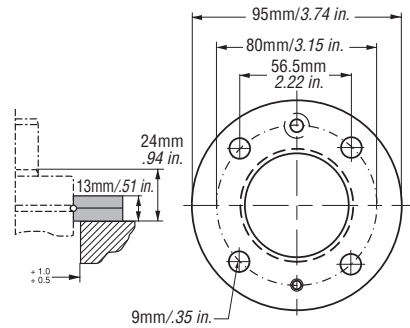

FCS

Order No. T2-750-FCS

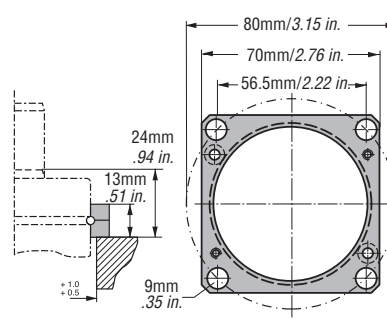

SF

Order No. T2-750-SF

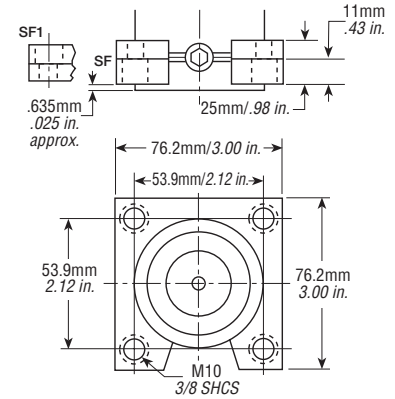

BFT

Order No. T2-750-BFT

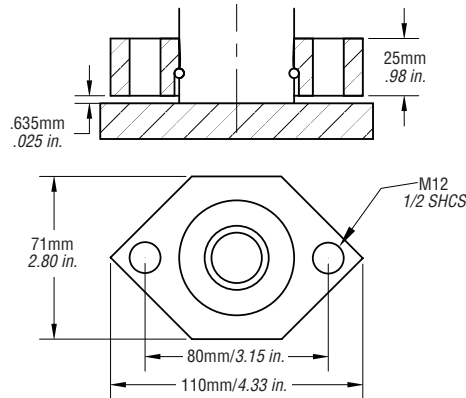

FMCW*

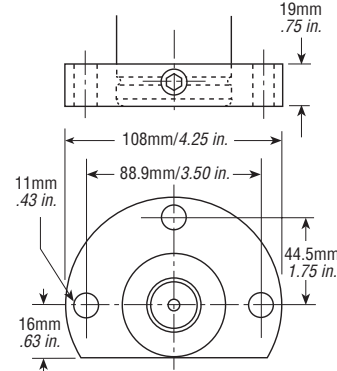

NOTE: This is a welded flange and not sold separately. Gas springs with welded flanges are not returnable.

FMW*

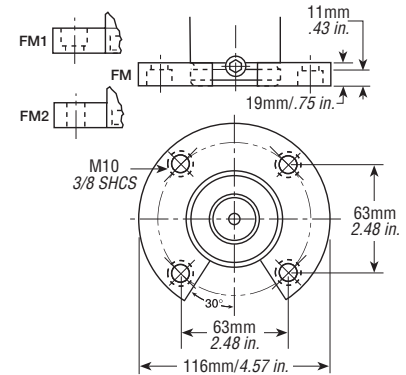

NOTE: This is a welded flange and not sold separately. Gas springs with welded flanges are not returnable.

LMW*

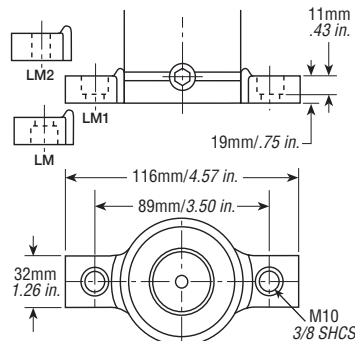

NOTE: This is a welded flange and not sold separately. Gas springs with welded flanges are not returnable.

TNKT 1000 Ordering Options

TNKT1000	X	50	—	FC	—	2175
Model		Stroke		Mount		Charge Pressure
		See Dimensional Information Chart		FC FCS SF BFT FMCW* FMW* LMW*		Max. 150 bar/ 2175 psi
All gas springs shipped at maximum charge pressure unless otherwise specified.						

*Counterbore must be specified.



TNKT 2400



Product Specifications

Pressure Medium.....Nitrogen Gas

Maximum Charging Pressure..... 150 bar/2175 psi

Minimum Charging Pressure..... 25 bar/360 psi

Max. Operating Temperature 80°C/176°F

Maximum Piston Rod Velocity96m/min / 315ft/min

Maximum Utilized Stroke 100%

Maximum Strokes per Minute..... ~20-100 (dependent on stroke)

Repair Kit 60-175-7000

Inlet Valve.....56-072-5500

Charge Fitting.....T2-770-4

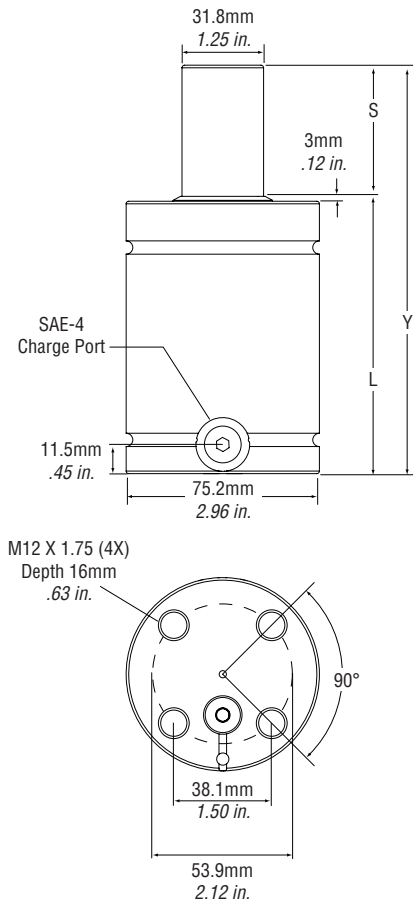

TNKT 2400 Dimensional Information

Model X Stroke	Stroke (S)		Contact Force		Full Stroke Force		L		Y	
	mm	in	N	lbs	N	lbs	mm	in	mm	in
TNKT2400X16	16	0.63	23,300	5,238	37,120	8,345	75	2.95	91	3.58
TNKT2400X19	19	0.75			37,655	8,465	78	3.07	97	3.82
TNKT2400X25	25	0.98			38,410	8,635	84	3.31	109	4.29
TNKT2400X32	32	1.26			38,990	8,765	91	3.58	123	4.84
TNKT2400X38	38	1.50			39,345	8,845	97	3.82	135	5.31
TNKT2400X50	50	1.97			39,810	8,950	109	4.29	159	6.26
TNKT2400X63	63	2.48			40,125	9,020	122	4.80	185	7.28
TNKT2400X75	75	2.95			40,325	9,065	134	5.28	209	8.23
TNKT2400X80	80	3.15			40,390	9,080	139	5.47	219	8.62
TNKT2400X100	100	3.94			40,590	9,125	159	6.26	259	10.20
TNKT2400X125	125	4.92			40,770	9,165	184	7.24	309	12.17
TNKT2400X150	150	5.91			40,880	9,190	220	8.66	370	14.57
TNKT2400X175	175	6.89			40,970	9,210	245	9.65	420	16.54
TNKT2400X200	200	7.87			41,035	9,225	270	10.63	470	18.50

NOTE: All dimensions are nominal. Data shown are typical. Actual data for any particular unit may vary.



Mounting Options

FC

Order No. T2-1500-FC

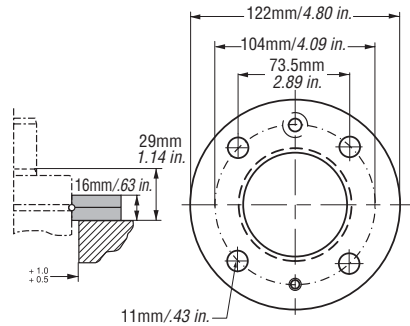

FCS

Order No. T2-1500-FCS

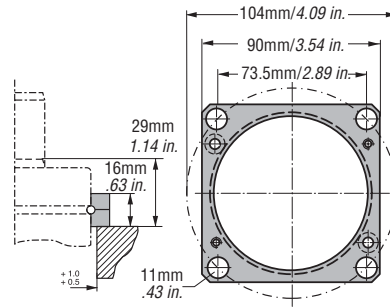

SF

Order No. T2-1500-SF

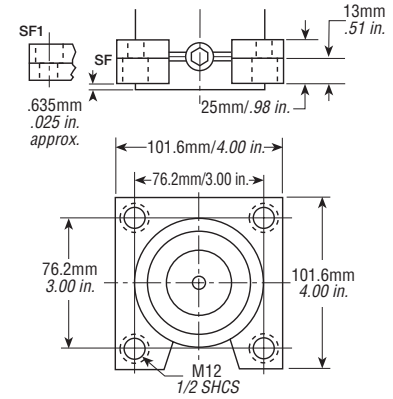

BFT

Order No. T2-1500-BFT

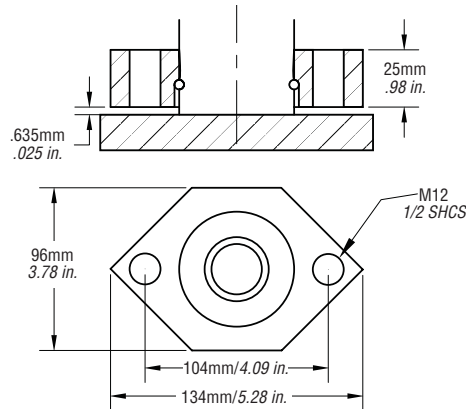

FMCW*

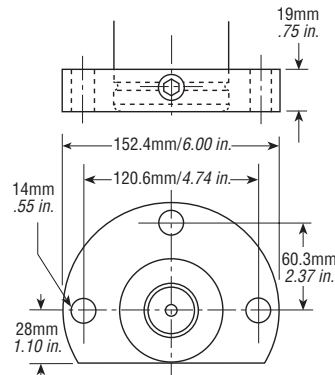

NOTE: This is a welded flange and not sold separately. Gas springs with welded flanges are not returnable.

FMW*

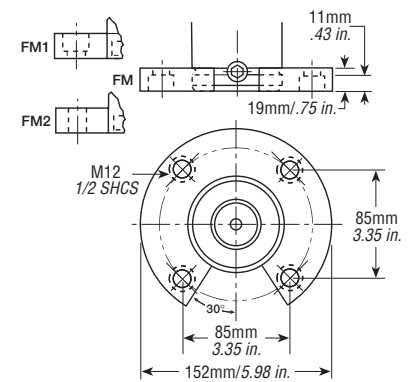

NOTE: This is a welded flange and not sold separately. Gas springs with welded flanges are not returnable.

LMW*

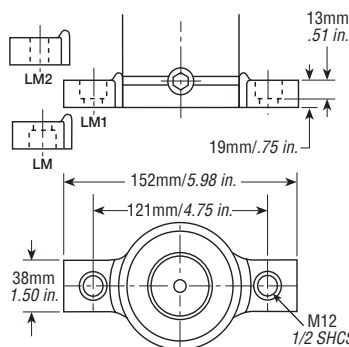

NOTE: This is a welded flange and not sold separately. Gas springs with welded flanges are not returnable.

TNKT 2400 Ordering Options

TNKT2400	X	200	—	SF	—	2175
Model		Stroke		Mount		Charge Pressure
		See Dimensional Information Chart		FC FCS SF BFT FMCW* FMW* LMW*		Max. 150 bar/ 2175 psi
All gas springs shipped at maximum charge pressure unless otherwise specified.						

*Counterbore must be specified.



TNKT 4200



Product Specifications

- Pressure Medium.....Nitrogen Gas
- Maximum Charging Pressure..... 150 bar/2175 psi
- Minimum Charging Pressure..... 25 bar/360 psi
- Max. Operating Temperature 80°C/176°F
- Maximum Piston Rod Velocity96m/min / 315ft/min
- Maximum Utilized Stroke 100%
- Maximum Strokes per Minute..... ~20-100 (dependent on stroke)
- Repair Kit60-238-7000
- Inlet Valve.....56-072-5500
- Charge Fitting..... T2-770-4

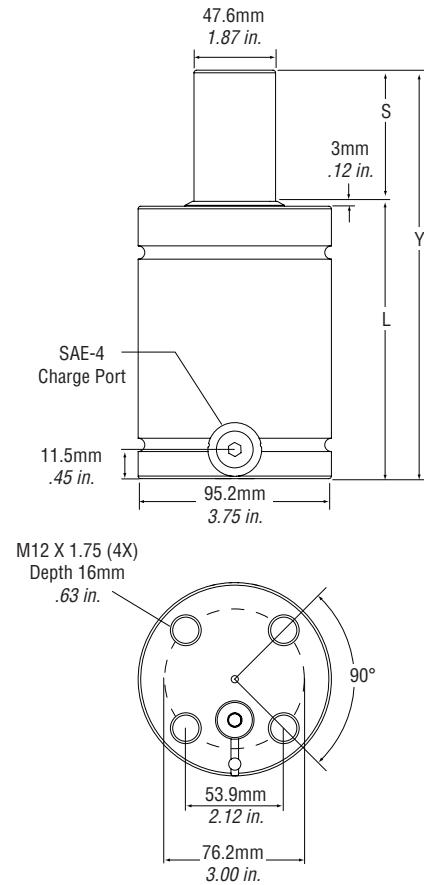

TNKT 4200 Dimensional Information

Model X Stroke	Stroke (S)		Contact Force		Full Stroke Force		L		Y	
	mm	in	N	lbs	N	lbs	mm	in	mm	in
TNKT4200X16	16	0.63	42,900	9,645	68,545	15,410	78	3.07	94	3.70
TNKT4200X19	19	0.75			69,705	15,670	81	3.19	100	3.94
TNKT4200X25	25	0.98			71,370	16,045	87	3.43	112	4.41
TNKT4200X32	32	1.26			72,640	16,330	94	3.70	126	4.96
TNKT4200X38	38	1.50			73,395	16,500	100	3.94	138	5.43
TNKT4200X50	50	1.97			74,440	16,735	112	4.41	162	6.38
TNKT4200X63	63	2.48			75,155	16,895	125	4.92	188	7.40
TNKT4200X75	75	2.95			75,620	17,000	137	5.39	212	8.35
TNKT4200X80	80	3.15			75,775	17,035	142	5.59	222	8.74
TNKT4200X100	100	3.94			76,245	17,140	162	6.38	262	10.31
TNKT4200X125	125	4.92			76,620	17,225	187	7.36	312	12.28
TNKT4200X150	150	5.91			76,890	17,285	225	8.86	375	14.76
TNKT4200X175	175	6.89			77,090	17,330	250	9.84	425	16.73
TNKT4200X200	200	7.87			77,220	17,360	275	10.83	475	18.70
TNKT4200X225	225	8.86			77,330	17,385	300	11.81	525	20.67

NOTE: All dimensions are nominal. Data shown are typical. Actual data for any particular unit may vary.



Mounting Options

FC

Order No. T2-3000-FC

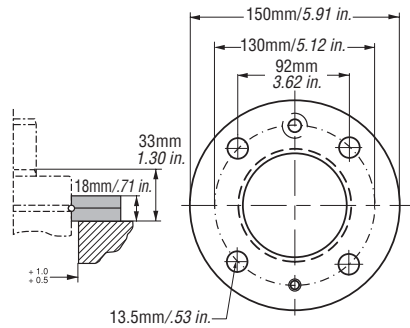

FCS

Order No. T2-3000-FCS

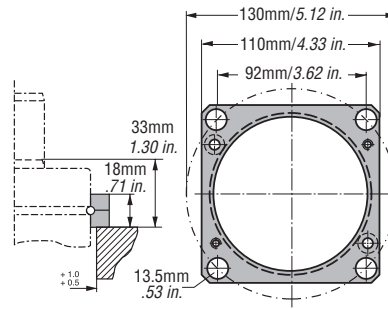

SF

Order No. T2-3000-SF

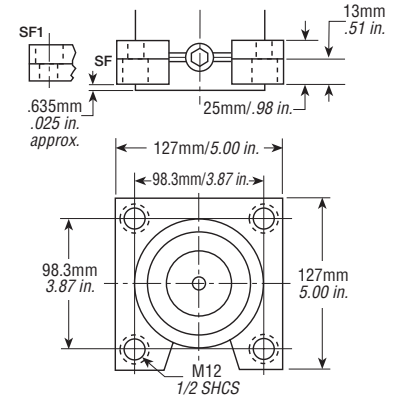

BFT

Order No. T2-3000-BFT

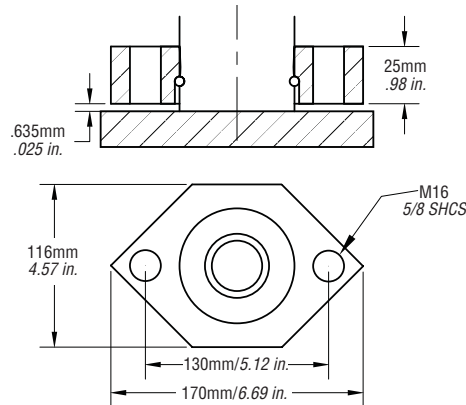

FMCW*

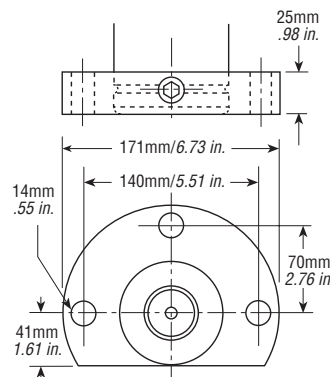

NOTE: This is a welded flange and not sold separately. Gas springs with welded flanges are not returnable.

FMW*

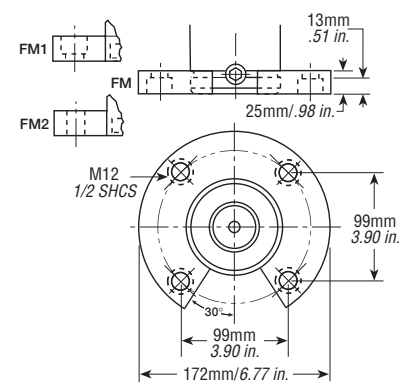

NOTE: This is a welded flange and not sold separately. Gas springs with welded flanges are not returnable.

LMW*

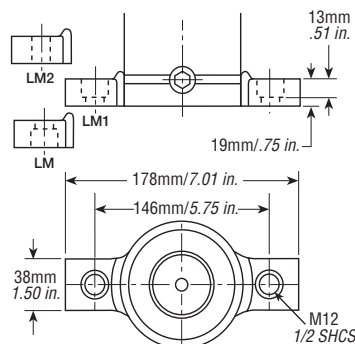

NOTE: This is a welded flange and not sold separately. Gas springs with welded flanges are not returnable.

TNKT 4200 Ordering Options

TNKT4200	X	80	—	SF	—	2175
Model		Stroke		Mount		Charge Pressure
		See Dimensional Information Chart		FC FCS SF BFT FMCW* FMW* LMW*		Max. 150 bar/ 2175 psi
All gas springs shipped at maximum charge pressure unless otherwise specified.						

*Counterbore must be specified.



TNKT 6600



Product Specifications

- Pressure Medium.....Nitrogen Gas
- Maximum Charging Pressure..... 150 bar/2175 psi
- Minimum Charging Pressure..... 25 bar/360 psi
- Max. Operating Temperature 80°C/176°F
- Maximum Piston Rod Velocity96m/min / 315ft/min
- Maximum Utilized Stroke 100%
- Maximum Strokes per Minute..... ~20-100 (dependent on stroke)
- Repair Kit 60-300-7000
- Inlet Valve.....56-072-5500
- Charge Fitting..... T2-770-4

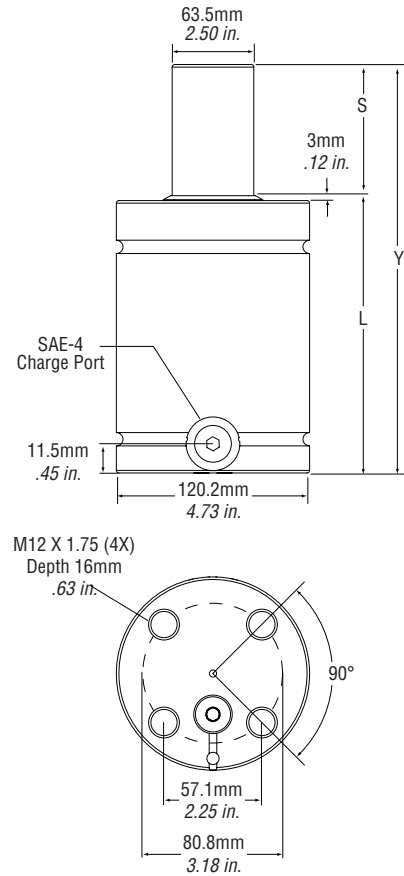

TNKT 6600 Dimensional Information

Model X Stroke	Stroke (S)		Contact Force		Full Stroke Force		L		Y	
	mm	in	N	lbs	N	lbs	mm	in	mm	in
TNKT6600X16	16	0.63	68,435	15,385	99,285	22,320	88	3.46	104	4.09
TNKT6600X19	19	0.75			101,910	22,910	91	3.58	110	4.33
TNKT6600X25	25	0.98			106,000	23,830	97	3.82	122	4.80
TNKT6600X32	32	1.26			109,495	24,615	104	4.09	136	5.35
TNKT6600X38	38	1.50			111,740	25,120	110	4.33	148	5.83
TNKT6600X50	50	1.97			115,030	25,860	122	4.80	172	6.77
TNKT6600X63	63	2.48			117,455	26,405	135	5.31	198	7.80
TNKT6600X75	75	2.95			119,080	26,770	147	5.79	222	8.74
TNKT6600X80	80	3.15			119,635	26,895	152	5.98	232	9.13
TNKT6600X100	100	3.94			121,370	27,285	172	6.77	272	10.71
TNKT6600X125	125	4.92			122,860	27,620	197	7.76	322	12.68
TNKT6600X150	150	5.91			123,905	27,855	235	9.25	385	15.16
TNKT6600X175	175	6.89			124,660	28,025	260	10.24	435	17.13
TNKT6600X200	200	7.87			125,260	28,160	285	11.22	485	19.09
TNKT6600X225	225	8.86			125,705	28,260	310	12.20	535	21.06

NOTE: All dimensions are nominal. Data shown are typical. Actual data for any particular unit may vary.



Mounting Options

FC

Order No. T2-5000-FC

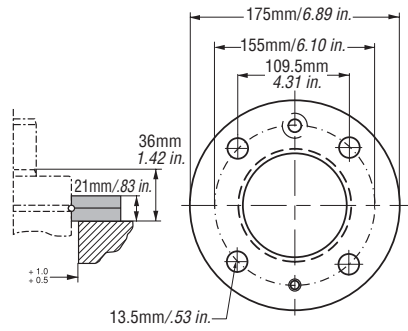

FCS

Order No. T2-5000-FCS

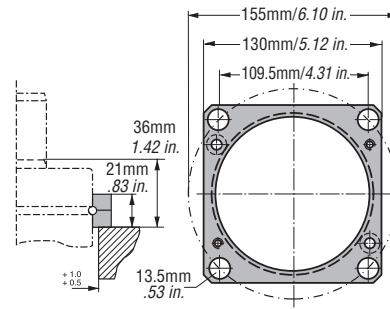

SF

Order No. T2-5000-SF

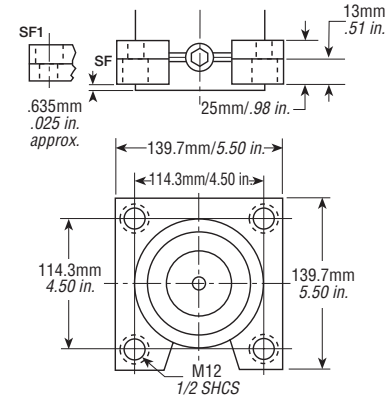

BFT

Order No. T2-5000-BFT

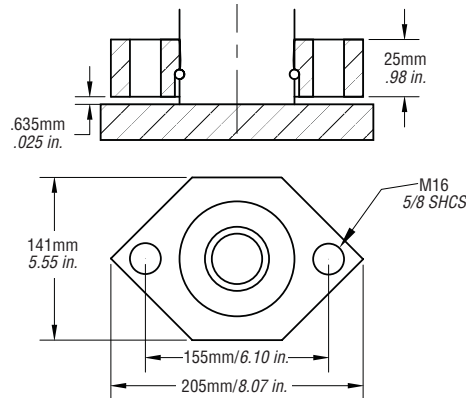

FMCW*

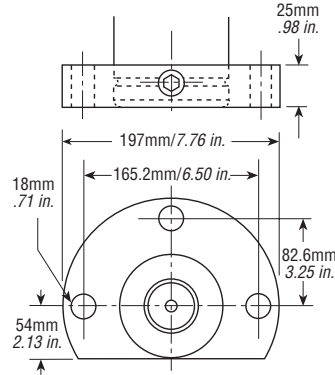

NOTE: This is a welded flange and not sold separately. Gas springs with welded flanges are not returnable.

FMW*

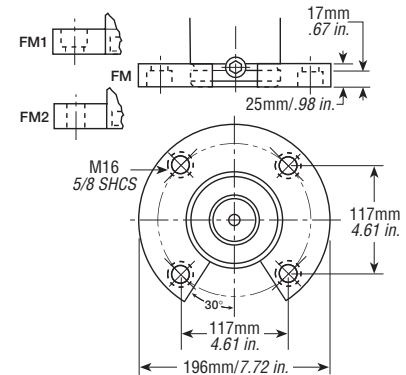

NOTE: This is a welded flange and not sold separately. Gas springs with welded flanges are not returnable.

LMW*

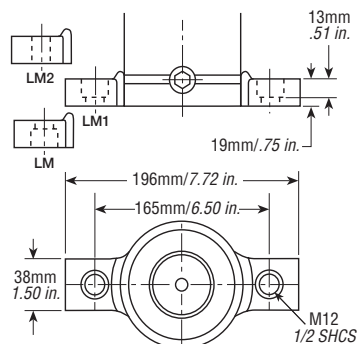

NOTE: This is a welded flange and not sold separately. Gas springs with welded flanges are not returnable.

TNKT 6600 Ordering Options

TNKT6600	X	100	—	FCS	—	2175
Model		Stroke		Mount		Charge Pressure
		See Dimensional Information Chart		FC FCS SF BFT FMCW* FMW* LMW*		Max. 150 bar/ 2175 psi
All gas springs shipped at maximum charge pressure unless otherwise specified.						

*Counterbore must be specified.



TNKT Force Charts

Note: To calculate Newtons, multiply Lbs. force by 4.448.

TNKT 1000 Force Chart (Lbs. force at 150 bar/2175 psi)																
mm	0	13	16	19	25	32	38	50	63	75	80	100	125	150	175	200
13	2,160	3,660														
16	2,160	3,130	3,710													
19	2,160	2,875	3,265	3,745												
25	2,160	2,630	2,860	3,135	3,790											
32	2,160	2,495	2,650	2,830	3,250	3,825										
38	2,160	2,430	2,550	2,690	3,010	3,435	3,840									
50	2,160	2,355	2,440	2,535	2,750	3,030	3,295	3,870								
63	2,160	2,310	2,370	2,445	2,600	2,810	3,000	3,410	3,885							
75	2,160	2,280	2,335	2,390	2,520	2,685	2,835	3,165	3,540	3,895						
80	2,160	2,275	2,320	2,375	2,495	2,645	2,785	3,085	3,430	3,760	3,900					
100	2,160	2,250	2,285	2,325	2,420	2,535	2,645	2,870	3,130	3,380	3,485	3,910				
125	2,160	2,230	2,260	2,290	2,360	2,450	2,535	2,710	2,910	3,100	3,180	3,505	3,920			
150	2,160	2,220	2,240	2,270	2,325	2,400	2,465	2,610	2,770	2,925	2,990	3,250	3,585	3,925		
175	2,160	2,210	2,230	2,250	2,300	2,360	2,420	2,540	2,675	2,805	2,860	3,080	3,360	3,645	3,930	
200	2,160	2,205	2,220	2,240	2,280	2,335	2,385	2,490	2,605	2,715	2,765	2,955	3,195	3,440	3,685	3,935

TNKT 2400 Force Chart (Lbs. force at 150 bar/2175 psi)															
mm	0	16	19	25	32	38	50	63	75	80	100	125	150	175	200
16	5,230	8,345													
19	5,230	7,700	8,465												
25	5,230	6,975	7,500	8,635											
32	5,230	6,530	6,915	7,740	8,765										
38	5,230	6,300	6,610	7,280	8,105	8,845									
50	5,230	6,015	6,245	6,725	7,325	7,855	8,950								
63	5,230	5,840	6,015	6,390	6,850	7,255	8,095	9,020							
75	5,230	5,735	5,880	6,190	6,570	6,905	7,590	8,355	9,065						
80	5,230	5,705	5,840	6,125	6,480	6,790	7,430	8,140	8,805	9,080					
100	5,230	5,605	5,710	5,935	6,215	6,455	6,960	7,515	8,035	8,250	9,125				
125	5,230	5,525	5,610	5,790	6,005	6,200	6,595	7,030	7,440	7,610	8,300	9,165			
150	5,230	5,475	5,545	5,690	5,870	6,030	6,355	6,715	7,055	7,195	7,760	8,475	9,190		
175	5,230	5,440	5,500	5,625	5,775	5,910	6,190	6,495	6,780	6,900	7,385	7,990	8,600	9,210	
200	5,230	5,415	5,465	5,575	5,705	5,825	6,065	6,330	6,580	6,685	7,105	7,630	8,160	8,690	9,225

TNKT 4200 Force Chart (Lbs. force at 150 bar/2175 psi)																
mm	0	16	19	25	32	38	50	63	75	80	100	125	150	175	200	225
16	9,635	15,410														
19	9,635	14,340	15,670													
25	9,635	13,065	14,025	16,045												
32	9,635	12,245	12,965	14,480	16,330											
38	9,635	11,800	12,395	13,640	15,165	16,500										
50	9,635	11,250	11,690	12,610	13,735	14,720	16,735									
63	9,635	10,900	11,245	11,965	12,840	13,605	15,175	16,895								
75	9,635	10,690	10,975	11,575	12,300	12,940	14,240	15,670	17,000							
80	9,635	10,620	10,890	11,450	12,125	12,720	13,935	15,270	16,515	17,035						
100	9,635	10,420	10,630	11,075	11,610	12,080	13,040	14,095	15,080	15,490	17,140					
125	9,635	10,260	10,425	10,775	11,205	11,575	12,340	13,175	13,955	14,280	15,585	17,225				
150	9,635	10,150	10,290	10,585	10,935	11,245	11,875	12,570	13,215	13,485	14,565	15,925	17,285			
175	9,635	10,075	10,195	10,445	10,745	11,010	11,550	12,140	12,690	12,920	13,845	15,000	16,165	17,330		
200	9,635	10,020	10,125	10,340	10,605	10,835	11,305	11,820	12,300	12,500	13,305	14,315	15,330	16,345	17,360	
225	9,635	9,975	10,070	10,260	10,495	10,700	11,115	11,575	12,000	12,175	12,890	13,785	14,685	15,585	16,485	17,385

TNKT 6600 Force Chart (Lbs. force at 150 bar/2175 psi)																
mm	0	16	19	25	32	38	50	63	75	80	100	125	150	175	200	225
16	15,375	22,320														
19	15,375	21,130	22,910													
25	15,375	19,665	20,975	23,830												
32	15,375	18,680	19,685	21,870	24,615											
38	15,375	18,135	18,975	20,790	23,070	25,120										
50	15,375	17,455	18,085	19,440	21,145	22,675	25,860									
63	15,375	17,015	17,510	18,580	19,915	21,115	23,610	26,405								
75	15,375	16,745	17,160	18,055	19,170	20,170	22,250	24,580	26,770							
80	15,375	16,660	17,045	17,880	18,925	19,865	21,810	23,985	26,035	26,895						
100	15,375	16,400	16,705	17,370	18,200	18,945	20,490	22,220	23,845	24,530	27,285					
125	15,375	16,190	16,435	16,965	17,625	18,220	19,450	20,825	22,115	22,660	24,850	27,620				
150	15,375	16,055	16,260	16,695	17,245	17,740	18,760	19,900	20,975	21,425	23,245	25,540	27,855			
175	15,375	15,955	16,130	16,505	16,975	17,395	18,270	19,245	20,160	20,545	22,100	24,065	26,040	28,025		
200	15,375	15,885	16,035	16,365	16,775	17,140	17,905	18,755	19,555	19,890	21,250	22,965	24,690	26,420	28,160	
225	15,375	15,825	15,960	16,255	16,615	16,945	17,620	18,375	19,085	19,385	20,590	22,110	23,640	25,175	26,720	28,260



TNKT Accessories

Service Gauge Assembly

Part No.: MGA-3000

Charging and discharging the TNKT for use in the self-contained mode is simple, when the MGA-3000 is used.

NOTE: Male quick disconnect charge fitting (T2-770-4) sold separately.



Male Quick Disconnect (Charge Fitting)

Part No. T2-770-4

The T2-770-4 quick disconnect is used along with the MGA-3000 service gauge assembly when charging and discharging TNKT Series gas springs in the self-contained mode.



Nitrogen Charging Assembly

Part Nos. NCA-2600 & NCA-2600-HP

The NCA-2600 charging assembly is used to transfer nitrogen from a commercial bottle to TNKT gas springs. The charging assembly includes a CGA-580 bottle fitting, regulator with bottle and system pressure gauges, shut-off valve and 10 feet of high pressure hose with a fitting for the control panel quick disconnect inlet or to the MGA-3000 service gauge assembly.

NOTE: The NCA-2600-HP is available for use with 3000-5000 psi bottles. CGA-680 bottle fitting provided with HP Series.



Seal Kits and Tool Kits

TNKT gas springs are field repairable. There is a seal kit with detailed instructions for each size gas spring. Tool kits are also available.

Gas Spring	Seal Kit Number	Tool Kit Number
TNKT1000	60-112-7000	T2TK-250-750
TNKT2400	60-175-7000	T2TK
TNKT4200	60-238-7000	
TNKT6600	60-300-7000	

Valve Removal and Installation Tool

Gas Spring	Tool Part Number
TNKT1000	T2TK-IN
TNKT2400	
TNKT4200	
TNKT6600	

NOTE: All dimensions are nominal. Data shown are typical. Actual data for any particular unit may vary.



TNKS 1000



Product Specifications

Pressure Medium.....Nitrogen Gas

Maximum Charging Pressure..... 150 bar/2175 psi

Minimum Charging Pressure..... 25 bar/360 psi

Max. Operating Temperature 80°C/176°F

Maximum Piston Rod Velocity96m/min / 315ft/min

Maximum Utilized Stroke 100%

Maximum Strokes per Minute..... ~20-100 (dependent on stroke)

Repair Kit 60-112-7000

Inlet Valve..... 4018112

Charge Fitting..... T2-770-T3

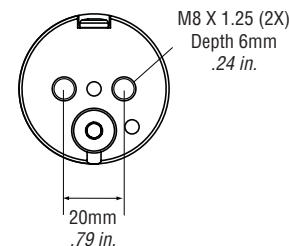
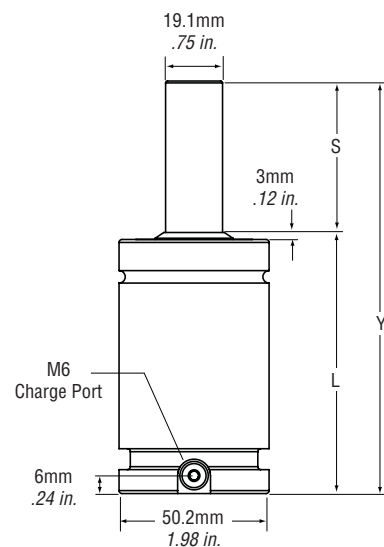

TNKS 1000 Dimensional Information

Model X Stroke	Stroke (S)		Contact Force		Full Stroke Force		L		Y	
	mm	in	N	lbs	N	lbs	mm	in	mm	in
TNKS1000X13	13	0.51	9,630	2,165	16,280	3,660	51	2.01	64	2.53
TNKS1000X16	16	0.63			16,505	3,710	54	2.13	70	2.76
TNKS1000X19	19	0.75			16,660	3,745	57	2.24	76	2.99
TNKS1000X25	25	0.98			16,860	3,790	63	2.48	88	3.46
TNKS1000X32	32	1.26			17,015	3,825	70	2.76	102	4.02
TNKS1000X38	38	1.50			17,080	3,840	76	2.99	114	4.49
TNKS1000X50	50	1.97			17,215	3,870	88	3.46	138	5.43
TNKS1000X63	63	2.48			17,280	3,885	101	3.98	164	6.46
TNKS1000X75	75	2.95			17,325	3,895	113	4.45	188	7.40
TNKS1000X80	80	3.15			17,350	3,900	118	4.65	198	7.80
TNKS1000X100	100	3.94			17,395	3,910	138	5.43	238	9.37
TNKS1000X125	125	4.92			17,435	3,920	163	6.41	288	11.34
TNKS1000X150	150	5.91			17,460	3,925	201	7.91	351	13.82
TNKS1000X175	175	6.89			17,480	3,930	226	8.90	401	15.79
TNKS1000X200	200	7.87			17,505	3,935	251	9.88	451	17.76

NOTE: All dimensions are nominal. Data shown are typical. Actual data for any particular unit may vary.



Mounting Options

FFC

Part No. T2-750-FFC

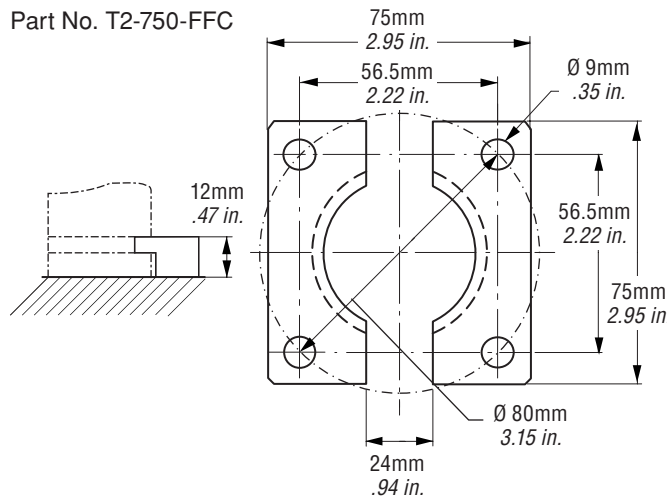

FC

Part No. T2-750-FC

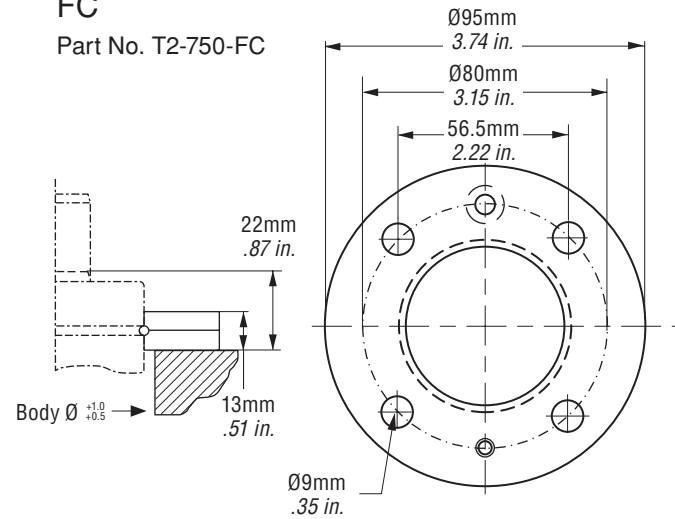

FCS

Part No. T2-750-FCS

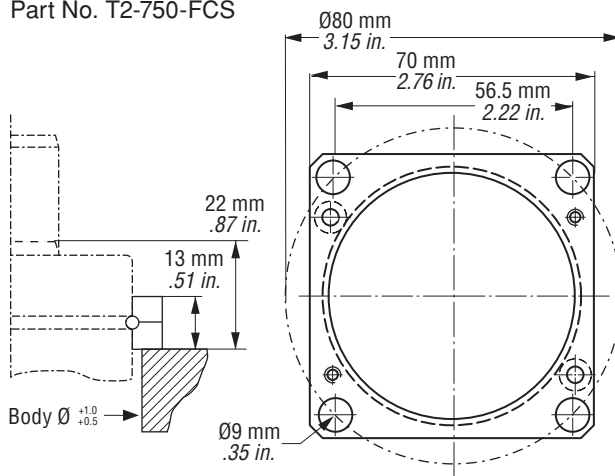

MP

Part No. T2-750-MP

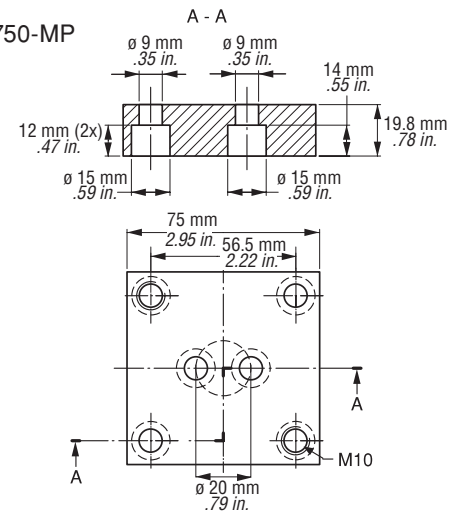

TNKS 1000 Ordering Options

TNKS1000	X	100	—	FCS	—	2175
Model		Stroke		Mount		Charge Pressure
		See Dimensional Information Chart		FFC FC FCS MP		Max. 150 bar/ 2175 psi
All gas springs shipped at maximum charge pressure unless otherwise specified.						



TNKS 2400



Product Specifications

Pressure Medium.....Nitrogen Gas
 Maximum Charging Pressure..... 150 bar/2175 psi
 Minimum Charging Pressure..... 25 bar/360 psi
 Max. Operating Temperature 80°C/176°F
 Maximum Piston Rod Velocity96m/min / 315ft/min
 Maximum Utilized Stroke 100%
 Maximum Strokes per Minute ~20-100 (dependent on stroke)
 Repair Kit 60-175-7000
 Inlet Valve..... 4018112
 Charge Fitting..... T2-770-T3

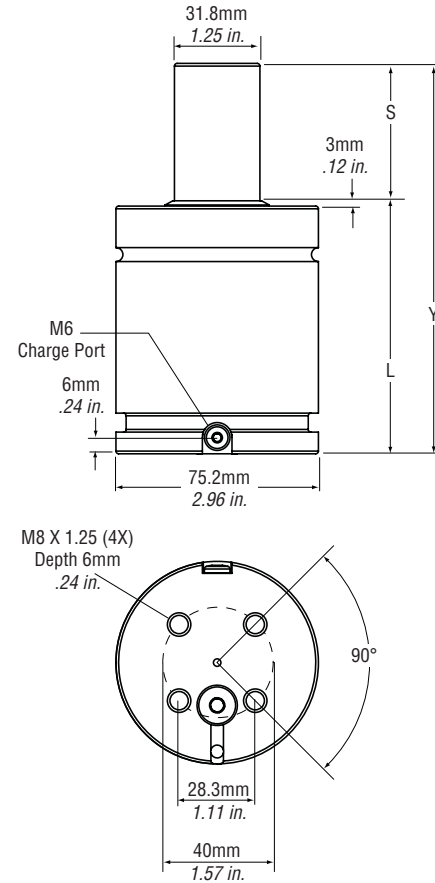

TNKS 2400 Dimensional Information

Model X Stroke	Stroke (S)		Contact Force		Full Stroke Force		L		Y	
	mm	in	N	lbs	N	lbs	mm	in	mm	in
TNKS2400X16	16	0.63	23,300	5,238	37,120	8,345	61	2.40	77	3.03
TNKS2400X19	19	0.75			37,655	8,465	64	2.52	83	3.27
TNKS2400X25	25	0.98			38,410	8,635	70	2.76	95	3.74
TNKS2400X32	32	1.26			38,990	8,765	77	3.03	109	4.29
TNKS2400X38	38	1.50			39,345	8,845	83	3.27	121	4.76
TNKS2400X50	50	1.97			39,810	8,950	95	3.74	145	5.71
TNKS2400X63	63	2.48			40,125	9,020	108	4.25	171	6.73
TNKS2400X75	75	2.95			40,325	9,065	120	4.72	195	7.68
TNKS2400X80	80	3.15			40,390	9,080	125	4.92	205	8.07
TNKS2400X100	100	3.94			40,590	9,125	145	5.71	245	9.65
TNKS2400X125	125	4.92			40,770	9,165	170	6.69	295	11.61
TNKS2400X150	150	5.91			40,880	9,190	206	8.11	356	14.02
TNKS2400X175	175	6.89			40,970	9,210	231	9.09	406	15.98
TNKS2400X200	200	7.87			41,035	9,225	256	10.08	456	17.95

NOTE: All dimensions are nominal. Data shown are typical. Actual data for any particular unit may vary.



Mounting Options

FFC

Part No. T2-1500-FFC

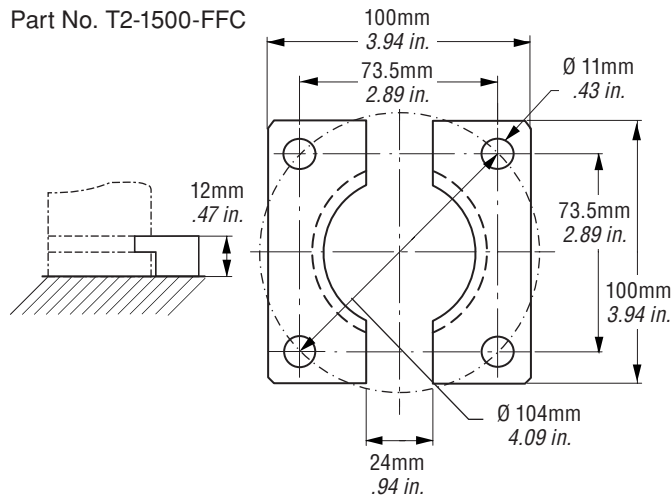

FC

Part No. T2-1500-FC

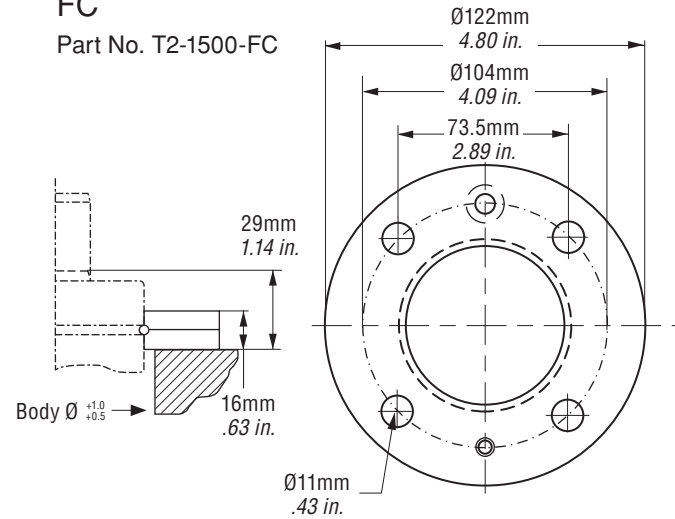

FCS

Part No. T2-1500-FCS

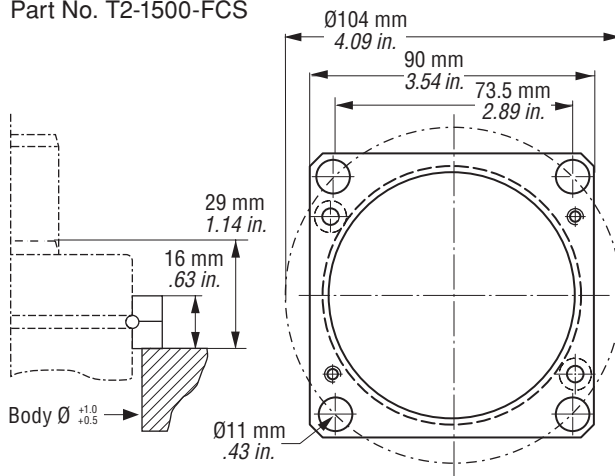

MP

Part No. T2-1500-MP

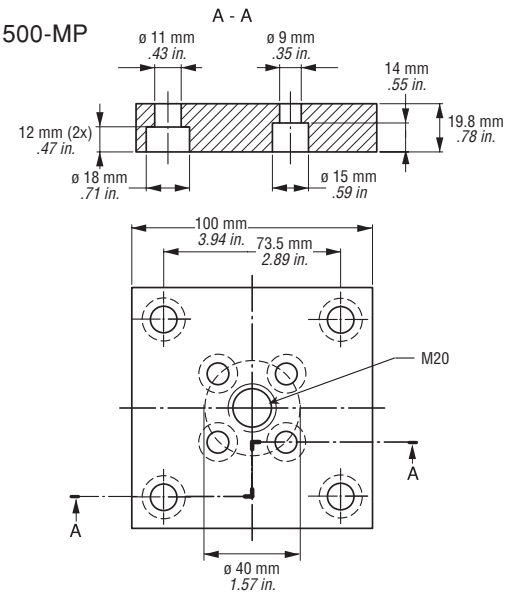

TNKS 2400 Ordering Options

TNKS2400	X	50	—	FC	—	2175
Model		Stroke		Mount		Charge Pressure
		See Dimensional Information Chart		FFC FC FCS MP		Max. 150 bar/ 2175 psi
All gas springs shipped at maximum charge pressure unless otherwise specified.						



TNKS 4200



Product Specifications

- Pressure Medium.....Nitrogen Gas
- Maximum Charging Pressure..... 150 bar/2175 psi
- Minimum Charging Pressure..... 25 bar/360 psi
- Max. Operating Temperature 80°C/176°F
- Maximum Piston Rod Velocity96m/min / 315ft/min
- Maximum Utilized Stroke 100%
- Maximum Strokes per Minute..... ~20-100 (dependent on stroke)
- Repair Kit 60-238-7000
- Inlet Valve.....56-072-5500
- Charge Fitting.....T2-770-G1/8-P

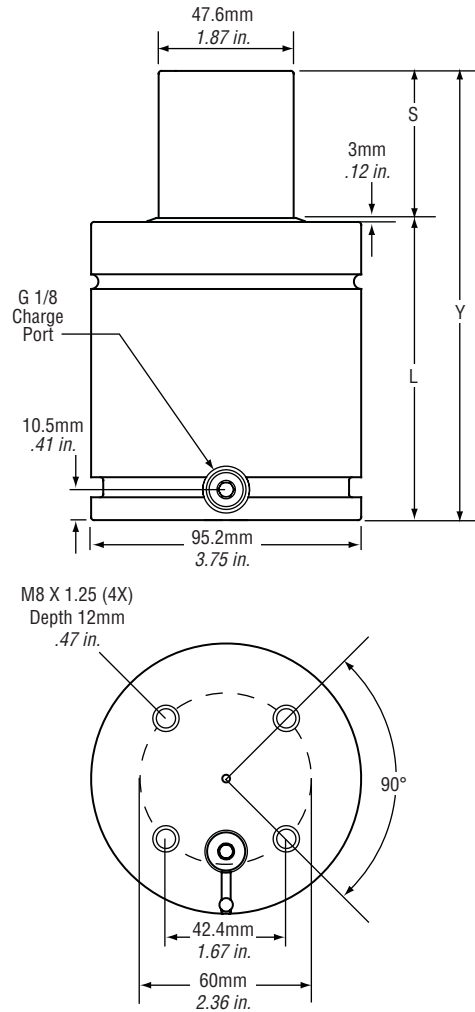

TNKS 4200 Dimensional Information

Model X Stroke	Stroke (S)		Contact Force		Full Stroke Force		L		Y	
	mm	in	N	lbs	N	lbs	mm	in	mm	in
TNKS4200X16	16	0.63	42,900	9,645	68,545	15,410	74	2.91	90	3.54
TNKS4200X19	19	0.75			69,705	15,670	77	3.03	96	3.78
TNKS4200X25	25	0.98			71,370	16,045	83	3.27	108	4.25
TNKS4200X32	32	1.26			72,640	16,330	90	3.54	122	4.80
TNKS4200X38	38	1.50			73,395	16,500	96	3.78	134	5.28
TNKS4200X50	50	1.97			74,440	16,735	108	4.25	158	6.22
TNKS4200X63	63	2.48			75,155	16,895	121	4.76	184	7.24
TNKS4200X75	75	2.95			75,620	17,000	133	5.24	208	8.19
TNKS4200X80	80	3.15			75,775	17,035	138	5.43	218	8.58
TNKS4200X100	100	3.94			76,245	17,140	158	6.22	258	10.16
TNKS4200X125	125	4.92			76,620	17,225	183	7.20	308	12.11
TNKS4200X150	150	5.91			76,890	17,285	221	8.70	371	14.61
TNKS4200X175	175	6.89			77,090	17,330	246	9.69	421	16.57
TNKS4200X200	200	7.87			77,220	17,360	271	10.67	471	18.54
TNKS4200X225	225	8.86			77,330	17,385	296	11.65	521	20.51

NOTE: All dimensions are nominal. Data shown are typical. Actual data for any particular unit may vary.



TNKS 6600



Product Specifications

Pressure Medium.....Nitrogen Gas

Maximum Charging Pressure..... 150 bar/2175 psi

Minimum Charging Pressure..... 25 bar/360 psi

Max. Operating Temperature 80°C/176°F

Maximum Piston Rod Velocity96m/min / 315ft/min

Maximum Utilized Stroke 100%

Maximum Strokes per Minute..... ~20-100 (dependent on stroke)

Repair Kit60-300-7000

Inlet Valve.....56-072-5500

Charge Fitting.....T2-770-G1/8-P

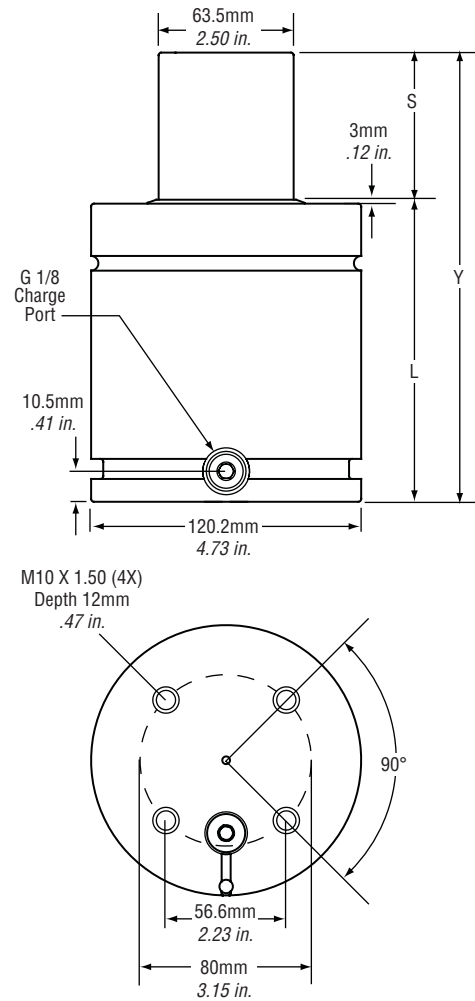

TNKS 6600 Dimensional Information

Model X Stroke	Stroke (S)		Contact Force		Full Stroke Force		L		Y	
	mm	in	N	lbs	N	lbs	mm	in	mm	in
TNKS6600X16	16	0.63	68,435	15,385	99,285	22,320	84	3.31	100	3.94
TNKS6600X19	19	0.75			101,910	22,910	87	3.43	106	4.17
TNKS6600X25	25	0.98			106,000	23,830	93	3.66	118	4.65
TNKS6600X32	32	1.26			109,495	24,615	100	3.94	132	5.20
TNKS6600X38	38	1.50			111,740	25,120	106	4.17	144	5.67
TNKS6600X50	50	1.97			115,030	25,860	118	4.65	168	6.61
TNKS6600X63	63	2.48			117,455	26,405	131	5.16	194	7.64
TNKS6600X75	75	2.95			119,080	26,770	143	5.63	218	8.58
TNKS6600X80	80	3.15			119,635	26,895	148	5.83	228	8.98
TNKS6600X100	100	3.94			121,370	27,285	168	6.61	268	10.55
TNKS6600X125	125	4.92			122,860	27,620	193	7.60	318	12.52
TNKS6600X150	150	5.91			123,905	27,855	231	9.09	381	15.00
TNKS6600X175	175	6.89			124,660	28,025	256	10.08	431	16.97
TNKS6600X200	200	7.87			125,260	28,160	281	11.06	481	18.94
TNKS6600X225	225	8.86			125,705	28,260	306	12.05	531	20.91

NOTE: All dimensions are nominal. Data shown are typical. Actual data for any particular unit may vary.



Mounting Options

FFC

Part No. T2-5000-FFC

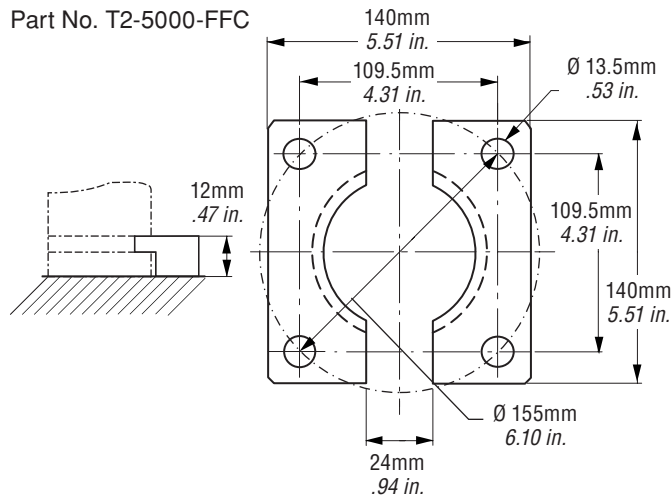

FC

Part No. T2-5000-FC

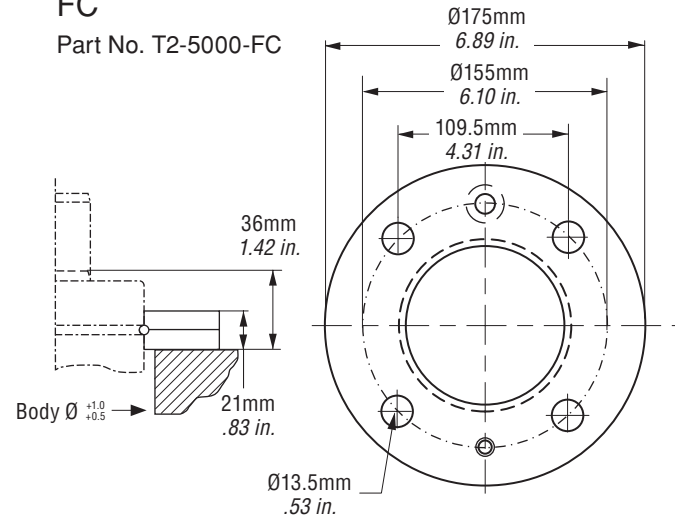

FCS

Part No. T2-5000-FCS

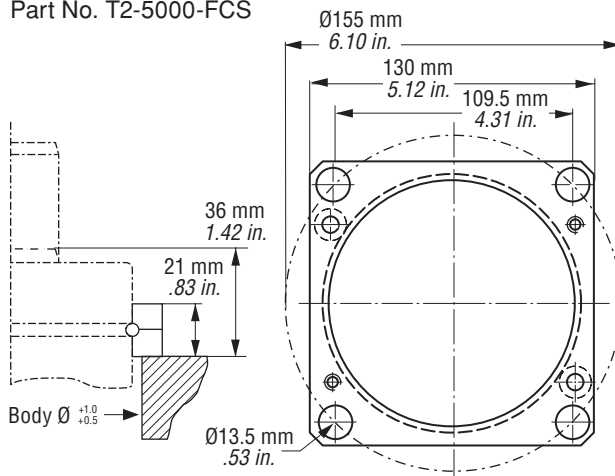

MP

Part No. T2-5000-MP

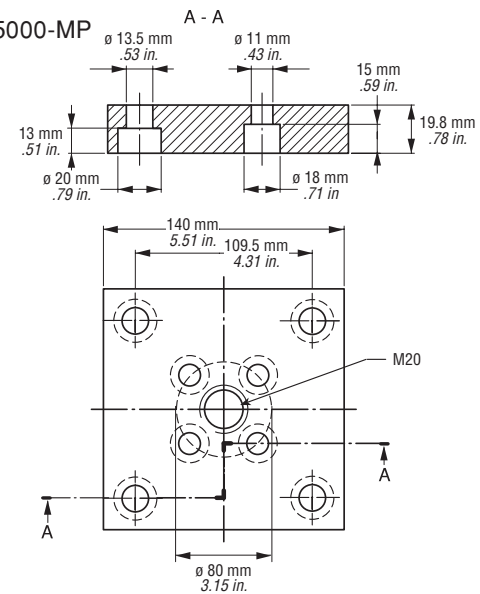

TNKS 6600 Ordering Options

TNKS6600	X	80	—	FFC	—	2175
Model		Stroke		Mount		Charge Pressure
		See Dimensional Information Chart		FFC FC FCS MP		Max. 150 bar/ 2175 psi
All gas springs shipped at maximum charge pressure unless otherwise specified.						



TNKS Force Charts

Note: To calculate Newtons, multiply Lbs. force by 4.448.

TNKS 1000 Force Chart (Lbs. force at 150 bar/2175 psi)																
mm	0	13	16	19	25	32	38	50	63	75	80	100	125	150	175	200
13	2,160	3,660														
16	2,160	3,130	3,710													
19	2,160	2,875	3,265	3,745												
25	2,160	2,630	2,860	3,135	3,790											
32	2,160	2,495	2,650	2,830	3,250	3,825										
38	2,160	2,430	2,550	2,690	3,010	3,435	3,840									
50	2,160	2,355	2,440	2,535	2,750	3,030	3,295	3,870								
63	2,160	2,310	2,370	2,445	2,600	2,810	3,000	3,410	3,885							
75	2,160	2,280	2,335	2,390	2,520	2,685	2,835	3,165	3,540	3,895						
80	2,160	2,275	2,320	2,375	2,495	2,645	2,785	3,085	3,430	3,760	3,900					
100	2,160	2,250	2,285	2,325	2,420	2,535	2,645	2,870	3,130	3,380	3,485	3,910				
125	2,160	2,230	2,260	2,290	2,360	2,450	2,535	2,710	2,910	3,100	3,180	3,505	3,920			
150	2,160	2,220	2,240	2,270	2,325	2,400	2,465	2,610	2,770	2,925	2,990	3,250	3,585	3,925		
175	2,160	2,210	2,230	2,250	2,300	2,360	2,420	2,540	2,675	2,805	2,860	3,080	3,360	3,645	3,930	
200	2,160	2,205	2,220	2,240	2,280	2,335	2,385	2,490	2,605	2,715	2,765	2,955	3,195	3,440	3,685	3,935

TNKS 2400 Force Chart (Lbs. force at 150 bar/2175 psi)																
mm	0	16	19	25	32	38	50	63	75	80	100	125	150	175	200	
16	5,230	8,345														
19	5,230	7,700	8,465													
25	5,230	6,975	7,500	8,635												
32	5,230	6,530	6,915	7,740	8,765											
38	5,230	6,300	6,610	7,280	8,105	8,845										
50	5,230	6,015	6,245	6,725	7,325	7,855	8,950									
63	5,230	5,840	6,015	6,390	6,850	7,255	8,095	9,020								
75	5,230	5,735	5,880	6,190	6,570	6,905	7,590	8,355	9,065							
80	5,230	5,705	5,840	6,125	6,480	6,790	7,430	8,140	8,805	9,080						
100	5,230	5,605	5,710	5,935	6,215	6,455	6,960	7,515	8,035	8,250	9,125					
125	5,230	5,525	5,610	5,790	6,005	6,200	6,595	7,030	7,440	7,610	8,300	9,165				
150	5,230	5,475	5,545	5,690	5,870	6,030	6,355	6,715	7,055	7,195	7,760	8,475	9,190			
175	5,230	5,440	5,500	5,625	5,775	5,910	6,190	6,495	6,780	6,900	7,385	7,990	8,600	9,210		
200	5,230	5,415	5,465	5,575	5,705	5,825	6,065	6,330	6,580	6,685	7,105	7,630	8,160	8,690	9,225	

TNKS 4200 Force Chart (Lbs. force at 150 bar/2175 psi)																
mm	0	16	19	25	32	38	50	63	75	80	100	125	150	175	200	225
16	9,635	15,410														
19	9,635	14,340	15,670													
25	9,635	13,065	14,025	16,045												
32	9,635	12,245	12,965	14,480	16,330											
38	9,635	11,800	12,395	13,640	15,165	16,500										
50	9,635	11,250	11,690	12,610	13,735	14,720	16,735									
63	9,635	10,900	11,245	11,965	12,840	13,605	15,175	16,895								
75	9,635	10,690	10,975	11,575	12,300	12,940	14,240	15,670	17,000							
80	9,635	10,620	10,890	11,450	12,125	12,720	13,935	15,270	16,515	17,035						
100	9,635	10,420	10,630	11,075	11,610	12,080	13,040	14,095	15,080	15,490	17,140					
125	9,635	10,260	10,425	10,775	11,205	11,575	12,340	13,175	13,955	14,280	15,585	17,225				
150	9,635	10,150	10,290	10,585	10,935	11,245	11,875	12,570	13,215	13,485	14,565	15,925	17,285			
175	9,635	10,075	10,195	10,445	10,745	11,010	11,550	12,140	12,690	12,920	13,845	15,000	16,165	17,330		
200	9,635	10,020	10,125	10,340	10,605	10,835	11,305	11,820	12,300	12,500	13,305	14,315	15,330	16,345	17,360	
225	9,635	9,975	10,070	10,260	10,495	10,700	11,115	11,575	12,000	12,175	12,890	13,785	14,685	15,585	16,485	17,385

TNKS 6600 Force Chart (Lbs. force at 150 bar/2175 psi)																
mm	0	16	19	25	32	38	50	63	75	80	100	125	150	175	200	225
16	15,375	22,320														
19	15,375	21,130	22,910													
25	15,375	19,665	20,975	23,830												
32	15,375	18,680	19,685	21,870	24,615											
38	15,375	18,135	18,975	20,790	23,070	25,120										
50	15,375	17,455	18,085	19,440	21,145	22,675	25,860									
63	15,375	17,015	17,510	18,580	19,915	21,115	23,610	26,405								
75	15,375	16,745	17,160	18,055	19,170	20,170	22,250	24,580	26,770							
80	15,375	16,660	17,045	17,880	18,925	19,865	21,810	23,985	26,035	26,895						
100	15,375	16,400	16,705	17,370	18,200	18,945	20,490	22,220	23,845	24,530	27,285					
125	15,375	16,190	16,435	16,965	17,625	18,220	19,450	20,825	22,115	22,660	24,850	27,620				
150	15,375	16,055	16,260	16,695	17,245	17,740	18,760	19,900	20,975	21,425	23,245	25,540	27,855			
175	15,375	15,955	16,130	16,505	16,975	17,395	18,270	19,245	20,160	20,545	22,100	24,065	26,040	28,025		
200	15,375	15,885	16,035	16,365	16,775	17,140	17,905	18,755	19,555	19,890	21,250	22,965	24,690	26,420	28,160	
225	15,375	15,825	15,960	16,255	16,615	16,945	17,620	18,375	19,085	19,385	20,590	22,110	23,640	25,175	26,720	28,260



TNKS Accessories

Service Gauge Assembly

Part No.: MGA-3000

Charging and discharging the TNKS for use in the self-contained mode is simple, when the MGA-3000 is used.

NOTE: Male quick disconnect charge fitting sold separately.



Male Quick Disconnect (Charge Fitting)

Part Nos. T2-770-T3 and T2-770-G1/8-P

The T2-770-T3 is used to charge TNKS1000 and 2400 models, while TNKS4200 and 6600 use the T2-770-G1/8-P.



T2-770-T3



T2-770-G1/8-P

Nitrogen Charging Assembly

Part Nos. NCA-2600 & NCA-2600-HP

The NCA-2600 charging assembly is used to transfer nitrogen from a commercial bottle to TNKS gas springs. The charging assembly includes a CGA-580 bottle fitting, regulator with bottle and system pressure gauges, shut-off valve and 10 feet of high pressure hose with a fitting for the control panel quick disconnect inlet or to the MGA-3000 service gauge assembly.

NOTE: The NCA-2600-HP is available for use with 3000-5000 psi bottles. CGA-680 bottle fitting provided with HP Series.



Seal Kits and Tool Kits

TNKS gas springs are field repairable. There is a seal kit with detailed instructions for each size gas spring. Tool kits are also available.

Gas Spring	Seal Kit Number	Tool Kit Number
TNKS1000	60-112-7000	T2TK-250-750
TNKS2400	60-175-7000	T2TK
TNKS4200	60-238-7000	
TNKS6600	60-300-7000	

Valve Removal and Installation Tool

Gas Spring	Tool Part Number
TNKS1000	T2TK-IN-M6
TNKS2400	
TNKS4200	T2TK-IN-G1/8
TNKS6600	

NOTE: All dimensions are nominal. Data shown are typical. Actual data for any particular unit may vary.