

SLIDE **LOCK**™

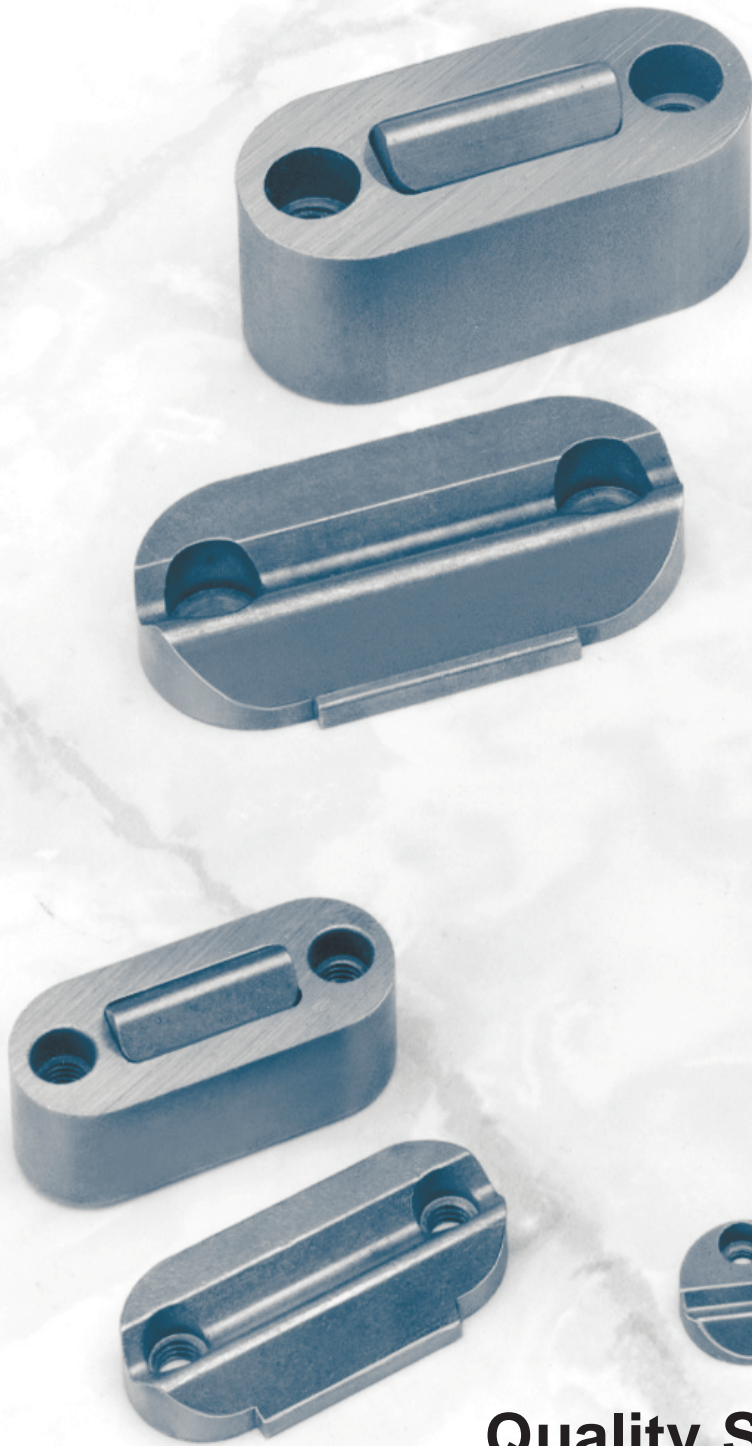

**Quality Slide
Retention Components**



Superior Slide-Locks are designed to effectively prevent operational slipping of the slide in your mold base.

Slide-Lock components are compact and hold their rated weights without hydraulics or other complicated devices and can be used in multiples to achieve greater weight retention. The simplicity of the Slide-Lock design allows dependable, repetitive mold base slide motion and can help minimize production halts.

QUALITY

High strength tool alloy construction provides durable production life. Slide-Lock components resist wear over many slide cycles.

COMPATIBILITY

Superior Slide-Locks are recessed into the slide for neat installation and can also be retrofitted into existing slides. Simple pocket machining is all you need to install Slide-Locks.

FEATURES:

- Compact, fits with the mold base.
- No protruding hardware on the mold base exterior.
- Ideal for use in space-confined areas.
- Large flat surface contact provides greater slide retention and positive locking.
- Easily machined into existing slides.
- Mounts with simple socket head cap screws.

NOTE A: For proper "Release Distance" see the Operating Data for each specific Slide-Lock™ model.

OPERATING DATA FOR ALL SLIDE-LOCKS

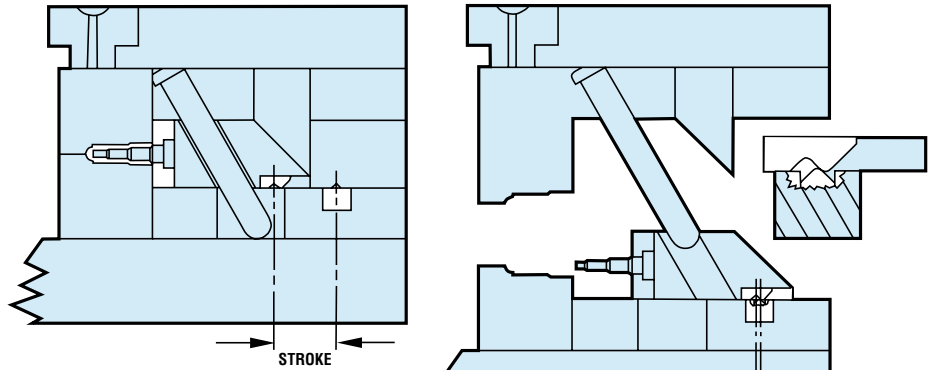

PLACE SLIDE-LOCK FROM CENTERLINE TO CENTERLINE OF STROKE

RELEASE DISTANCE (SEE NOTE A)

NOTE: SET ANGLE PIN TO RELEASE .020 TO .030" FROM FULL STROKE. SLIDE-LOCK WILL SNAP TO FULL STROKE TO ASSURE RE-ENTRY CLEARANCE.

SLK-8A MACHINING DATA

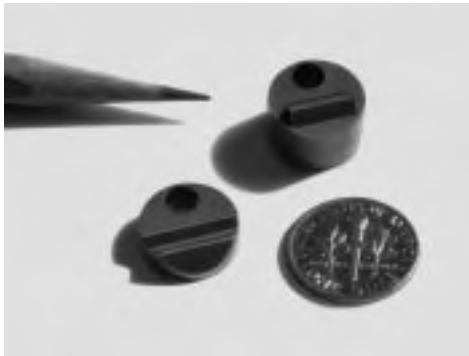

Patent #4,765,585

Slide-Lock model SLK-8A is rated to carry a weight of up to 8 pounds. Flat surface contact provides greater positive locking/unlocking action and more dependable operation over ball contact types. Ultra-compact design allows use in very limited installation space.

WHEN ORDERING PLEASE SPECIFY:

1. Part Number SLK-8A
2. Quantity

NOTE: 1. **X**, **▶** Indicates CAD Merge Point.

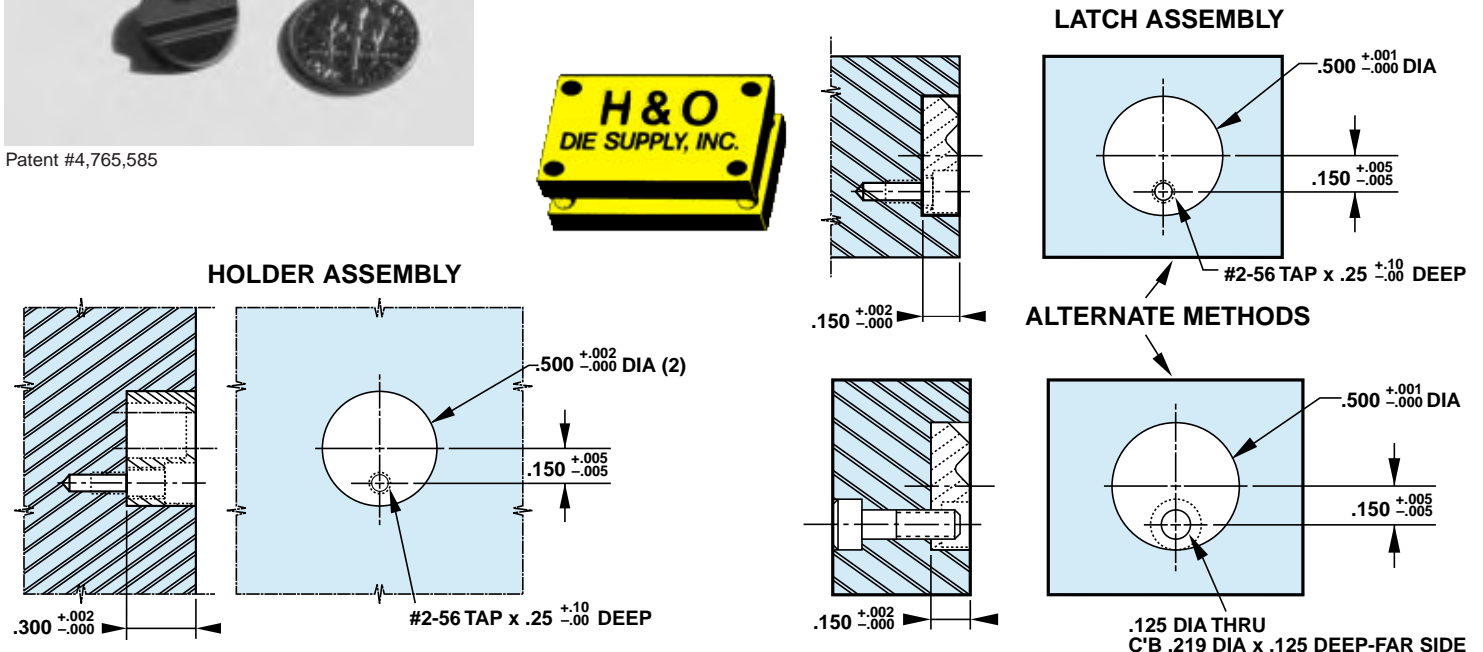



SLK-25A MACHINING DATA



Slide-Lock model SLK-25A is rated to carry a weight of up to 25 pounds. Easily machines into mold base slides and provides a neatly concealed slide-locking mechanism.

Patent #4,765,585

WHEN ORDERING PLEASE SPECIFY:

1. Part Number SLK-25A
2. Quantity

NOTE: 1. **X**, ► Indicates CAD Merge Point.

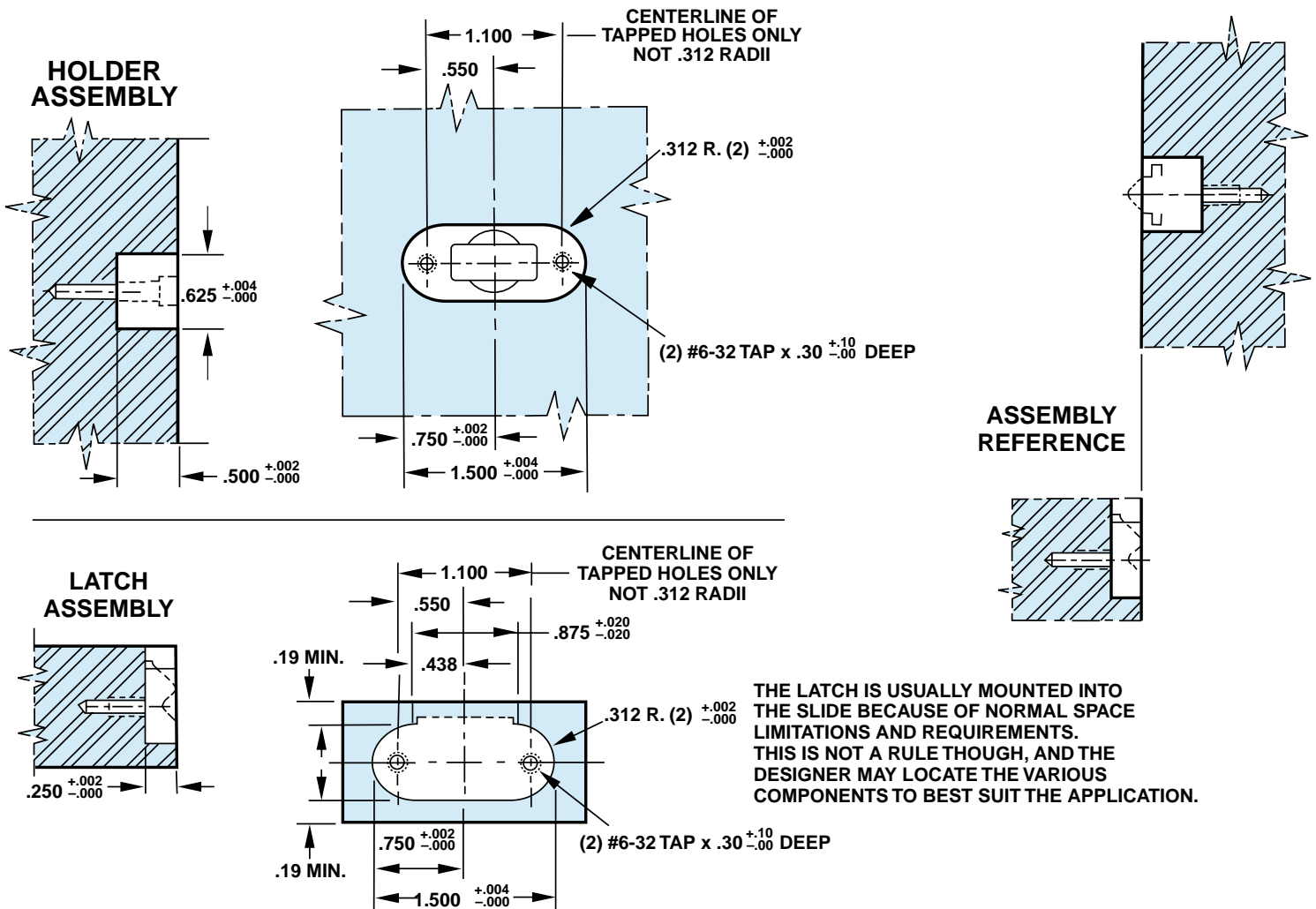

NEW

SLK-50A MACHINING DATA



Slide-Lock model SLK-50A is rated to carry a weight of up to 50 pounds. Ideal for die cast mold slide applications. Multiple Slide-Locks can be easily machined and mounted in mold slides for higher load retentions.

Patent #4,765,585

WHEN ORDERING PLEASE SPECIFY:

- 1. Part Number SLK-50A
- 2. Quantity

NOTE: 1. **X**, ► Indicates CAD Merge Point.

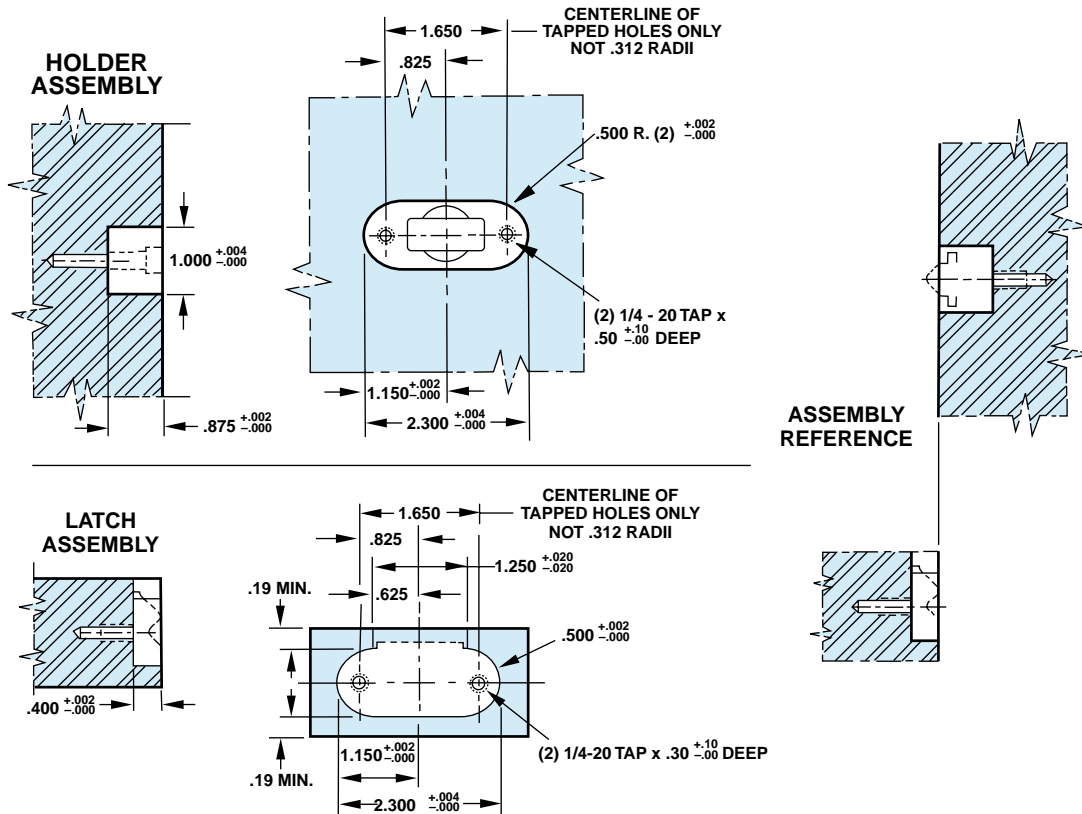

THE LATCH IS USUALLY MOUNTED INTO THE SLIDE BECAUSE OF NORMAL SPACE LIMITATIONS AND REQUIREMENTS. THIS IS NOT A RULE THOUGH, AND THE DESIGNER MAY LOCATE THE VARIOUS COMPONENTS TO BEST SUIT THE APPLICATION.



H&O Die Supply 7200 Interstate 20 Kennedale, TX 76060 www.hodie.com
Phone: 214-630-6660 Fax: 214-630-6693